

9000NCP/9000NCP2
VistaLINK™ Network Control Panel
Instruction Manual

© Copyright 2003, 2004

EVERTZ MICROSYSTEMS LTD.

5288 John Lucas Drive, Burlington, Ontario, Canada, L7L 5Z9

Phone: 905-335-3700

Fax: 905-335-3573

Internet: Sales: sales@evertz.com

Tech Support: service@evertz.com

Web Page: <http://www.evertz.com>

Version 1.7, October 2004

The material contained in this manual consists of information that is the property of Evertz Microsystems and is intended solely for the use of purchasers of the 9000NCP Series. Evertz Microsystems expressly prohibits the use of this manual for any purpose other than the operation of the 9000NCP Series.

All rights reserved. No part of this publication may be reproduced without the express written permission of Evertz Microsystems Ltd. Copies of this guide can be ordered from your Evertz products dealer or from Evertz Microsystems.

INFORMATION TO USERS IN EUROPE

NOTE

CISPR 22 CLASS A DIGITAL DEVICE OR PERIPHERAL

This equipment has been tested and found to comply with the limits for a Class A digital device, pursuant to the European Union EMC directive. These limits are designed to provide reasonable protection against harmful interference when the equipment is operated in a commercial environment. This equipment generates, uses, and can radiate radio frequency energy and, if not installed and used in accordance with the instruction manual, may cause harmful interference to radio communications. Operation of this equipment in a residential area is likely to cause harmful interference in which case the user will be required to correct the interference at his own expense.

INFORMATION TO USERS IN THE U.S.A.

NOTE

FCC CLASS A DIGITAL DEVICE OR PERIPHERAL

This equipment has been tested and found to comply with the limits for a Class A digital device, pursuant to Part 15 of the FCC Rules. These limits are designed to provide reasonable protection against harmful interference when the equipment is operated in a commercial environment. This equipment generates, uses, and can radiate radio frequency energy and, if not installed and used in accordance with the instruction manual, may cause harmful interference to radio communications. Operation of this equipment in a residential area is likely to cause harmful interference in which case the user will be required to correct the interference at his own expense.

WARNING

Changes or Modifications not expressly approved by Evertz Microsystems Ltd. could void the user's authority to operate the equipment.
Use of unshielded plugs or cables may cause radiation interference. Properly shielded interface cables with the shield connected to the chassis ground of the device must be used.

REVISION HISTORY

<u>REVISION</u>	<u>DESCRIPTION</u>	<u>DATE</u>
0.1	Preliminary version	Mar 03
1.0	First release version	Mar 03
1.1	Added support for 7710UC-HD	Sep 03
1.2	Added support for 7735CEM-X	Oct 03
1.3	Added support for the 7720AM-AES4	Jan 04
1.4	Updated NCP/NCP2, VistaLINK™ PRO and 7742DLY-HD	Feb 04
1.5	Added new NCP2 picture; updated 7745FS-HD+P Parameter	Feb 04
1.5a	Minor corrections	Feb 04
1.6	Additional product support: DCDA-HD and other 7700 series	Aug 04
1.7	Updated NCP features and new VistaLINK™ Configuration Control	Oct 04

- 1. OVERVIEW.....1
- 2. INSTALLATION.....3
 - 2.1. CONNECTING THE NETWORK CONTROL PANEL.....3
 - 2.2. POWER SUPPLY.....3
 - 2.3. MOUNTING.....3
 - 2.4. UPGRADING NCP NETWORK CONTROL PANEL FIRMWARE3
- 3. SPECIFICATIONS.....4
 - 3.1. SERIAL I/O (COM1).....4
 - 3.2. ETHERNET INPUT/OUTPUT.....4
 - 3.3. ELECTRICAL.....4
 - 3.4. PHYSICAL4
- 4. 9000NCP NETWORK CONTROL PANEL.....5
 - 4.1. 9000NCP FRONT PANEL OVERVIEW5
 - 4.1.1. Overview of FRAME SELECT Push-Button.....5
 - 4.1.2. Overview of the Display Line Selection Push-button Tools.....5
 - 4.1.3. Overview of Rotary Control and Push-button Tool.....5
 - 4.1.4. Overview of SETUP Push-Button6
 - 4.1.5. Overview of SELECT Push-Button6
 - 4.1.6. Overview of the PRESET CONFIGURATION Push-Buttons6
 - 4.1.7. Overview of SHIFT Push-Button6
 - 4.1.8. Overview of the PANEL LOCK Push-Button.....6
- 5. 9000NCP2 NETWORK CONTROL PANEL.....7
 - 5.1. 9000NCP2 FRONT PANEL OVERVIEW7
 - 5.1.1. Overview of the PRESET CONFIGURATION Push-Buttons7
 - 5.1.2. Overview of Rotary Control and Parameter Selection8
 - 5.1.3. Overview of SETUP Push-Button8
 - 5.1.4. Overview of SELECT Push-Button8
- 6. 9000NCP AND 9000NCP2 CONFIGURAITON MENU9
- 7. CONFIGURING NCP UNITS THROUGH VISTALINK™ PRO.....10
- 8. CONFIGURING VISTALINK™ ENABLED CARDS.....17

8.1. 7710DCDA-HD AND 500DCDA-HD..... 18

8.2. 7710UC-HD..... 19

8.3. 7710XC 21

8.4. 7711HDC-X AND 7712HDC-X 22

8.5. 7720AM-AES4 23

8.6. 7735AVC-LB..... 24

8.7. 7735CDM-x..... 25

8.8. 7735CEM-x 26

8.9. 7742DLY-HD AND 7743DLY-HD 27

8.10. 7745FS-EAES4-HD+P AND 7746FS(-EAES4)-HD 28

8.11. 7745FS-EAES+P 29

Figures

Figure 1: 9000NCP Network Control Panel 1

Figure 2: 9000NCP2 Network Control Panel 2

Figure 3: 9000NCP Front and Rear Views..... 5

Figure 4: 9000NCP2 Front and Rear Views..... 7

Figure 5: Quick Button Access Tab for 9000NCP 11

Figure 6: Masking Tab (Common to 9000NCP and 9000NCP2) 12

Figure 7: Hardware Configurations Tab (Common to 9000NCP and 9000NCP2) 12

Figure 8: Services Tab (Common to 9000NCP and 9000NCP2) 13

Figure 9: Manually Added IP Tab (Common to 9000NCP and 9000NCP2) 13

Figure 10: Server IP Tab (Common to 9000NCP and 9000NCP2)..... 14

Figure 11: Quick Button Access Tab for 9000NCP2..... 15

Figure 12: Quick Button Access Tab for 9000NCP2 in Split Mode 16

1. OVERVIEW

The 1RU 9000NCP and 2RU 9000NCP2 VistaLINK™ Network Control Panels (NCPs) are low-powered, rack mounted control panel interfaces to VistaLINK™-enabled frames and modules, allowing for real-time selection and configuration control of enabled parameters.

Both NCP units connect to the network via Ethernet, communicating via Simple Network Management Protocol (SNMP). In its simplest network configuration, either NCP can be directly connected to a single frame via the frame controller using a cross-over network cable. In advanced systems, multiple NCPs can be connected within the same network, each capable of configuring all addressable parameters in every networked frame, or limited to a certain, user-defined set of frames, cards or parameters. With Evertz's VistaLINK™ PRO server running on the same network, NCP units are further enabled with custom labels, preset quick-access configuration buttons and masking/privilege control.



Figure 1: 9000NCP Network Control Panel

9000NCP Features

- Low power, rack-mountable and compact 1RU control panel
- Single, 4-line, 24 alphanumeric digit per line vacuum fluorescent display (VFD) featuring very high brightness and widest viewing angles
- 16 (8+Shift Key) illuminated, tactile and full-size quick-access pushbuttons with position and selector rotary control (shaft encoder)
- Built-in Simple Network Management Protocol (SNMP) communication interface over Ethernet connection
- Operational configuration control of key VistaLINK™ enabled product parameters
- Quick-access preset button, frame and card labels, and configuration privilege controls available via VistaLINK™

9000NCP/NCP2 VistaLINK(TM) Network Control Panel



Figure 2: 9000NCP2 Network Control Panel

9000NCP2 Features

- Low power, rack-mountable, 2RU control panel
- Two, 4-line, 24 alphanumeric digit per line vacuum fluorescent display (VFD) featuring very high brightness and widest viewing angles
- 44 illuminated, tactile and full-size quick access pushbuttons with four position and selector rotary controls (shaft encoders)
- Provides convenient and fast configuration access for up to 4 simultaneous proc controls via split-screen display feature
- Built-in Simple Network Management Protocol (SNMP) communication interface over Ethernet connection
- Operational configuration control of key VistaLINK™ enabled product parameters
- Quick-access preset button, frame and card labels, and configuration privilege controls available via VistaLINK™

2. INSTALLATION

2.1. CONNECTING THE NETWORK CONTROL PANEL

There are two network connection options available for all NCP panels:

1. Using a straight-thru, Cat5 cable, connect one end to the RJ45 port on the rear of the NCP, and the other to a network switch or hub. This connection method is recommended if more than 2 network nodes (beyond the NCP and single frame) are anticipated on the same network.
2. Using a cross-over, Cat5 cable, connect one end to the RJ45 port on the rear of the NCP, and the other end directly to the RJ-45 of the connector on the rear panel of the 7700FC Frame Controller. This method is suggested only if one network connection will be used.

In either case, communication between the network panel and frame(s) is through Simple Network Management Protocol (SNMP).

The SERIAL I/O 9 pin D connector (COM1) at the rear of the NCP is used for firmware upgrades. COM2 port is currently not available.

2.2. POWER SUPPLY

LINE: Both 9000NCP and 9000NCP2 Network Control Panels have one universal power supply that operates on either 115 Volt / 60 Hz or 230 Volt / 50 Hz AC.

2.3. MOUNTING

VistaLINK™ Network Control Panels are equipped with rack mounting brackets and fit into a standard 19 inch by 1 3/4 inch (483 mm x 45 mm) rack space. The mounting brackets may be removed if rack mounting is not required.

2.4. UPGRADING NCP NETWORK CONTROL PANEL FIRMWARE

The 9000NCP and 9000NCP2 Network Control Panels' share the same firmware. The latest version is available on the Evertz website (in the "Downloads" section). Firmware is upgraded through the COM1 serial comm. port of either unit using the following instructions:

- Connect PC containing 9000NCP and/or 9000NCP2 binary file to COM1 and enable terminal emulation program (i.e. HyperTerminal)
- Set the terminal emulation parameter to:
 - 57600 bits per second
 - 8 data bits
 - no parity
 - 2 stop bits
 - no flow control
- With the comm. port connected and running terminal emulation, apply power to the NCP unit and upon boot-up, hit "CTRL-X" several times simultaneously to interrupt the boot-up process.
- Type "upgrade" at the prompt and <Enter>
- Select "Y" for yes to the upgrade question followed by <Enter>
- Send the binary file using the "X-modem" protocol option
- Upon completion, re-boot the NCP unit

3. SPECIFICATIONS

3.1. SERIAL I/O (COM1)

Standard: RS-232
Connector: Female DB-9
Baud Rate: 57600
Format: 8 bits, no parity, 2 stop bits, no hardware flow control
(COM2 not available)

3.2. ETHERNET INPUT/OUTPUT

Standard: IEEE 802.3 (10BaseT), IEEE 802.3u (100BaseTx)
Connector: 1 RJ45
Cable Requirements:
10 Base T: UTP category 3, 4 or 5 cable up to 328ft/100m (2 pairs)
100 Base Tx: UTP category 5 cable up to 328ft/100m (2 pairs)

3.3. ELECTRICAL

Voltage: + 12VDC
Power: 9 Watts (9000NCP), 11 Watts (9000NCP2)
EMI/RFI: Complies with FCC Part 15, class A and EU EMC directive.

3.4. PHYSICAL

Size: 9000NCP – 17 1/8" W x 4 3/8" D x 1 3/4" H
(435mm x 111mm x 45mm)
9000NCP2 – 17 1/8" W x 4 3/8" D x 3 1/2" H
(435mm x 111mm x 89mm)

Weight: 9000NCP – 3 lbs. (1.36 kg)
9000NCP2 – 4 lbs. (1.81 kg)

Temperature: 0 to 50 deg. C. (Operating)

4. 9000NCP NETWORK CONTROL PANEL

The display area consists of a 24 digit alphanumeric display, 8 preset configuration push-buttons (which, along with the “Shift” key enable up to 16 presets), 4 line select push-buttons, tactile rotary with push-button selection and panel lock. The keypad can be used to select a specific frame, card or parameter being addressed by the NCP and is configurable by the user.

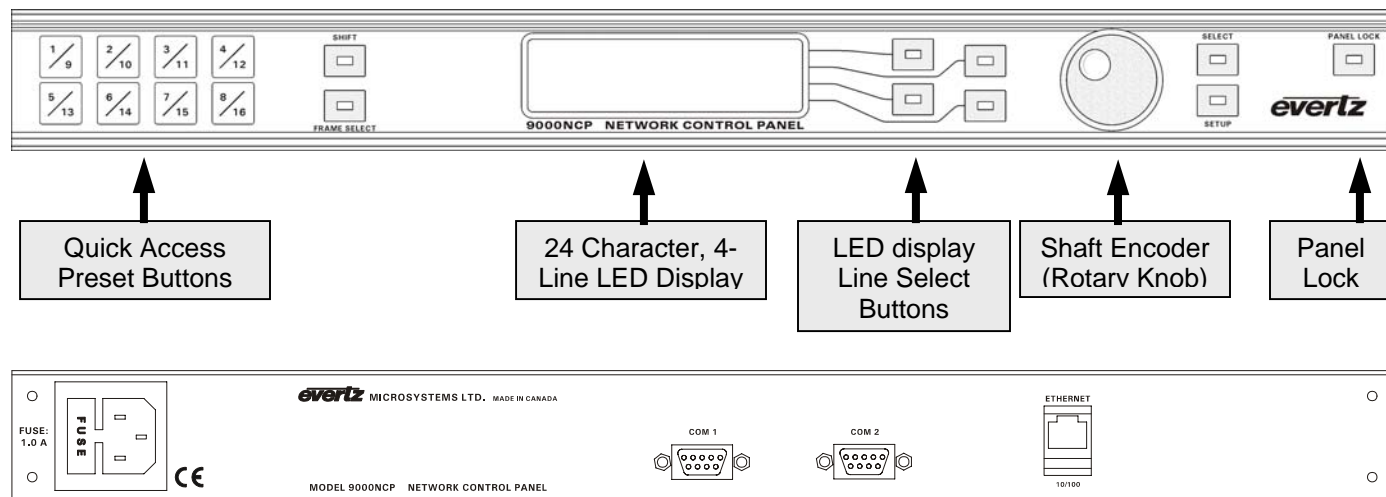

Figure 3: 9000NCP Front and Rear Views

4.1. 9000NCP FRONT PANEL OVERVIEW

4.1.1. Overview of FRAME SELECT Push-Button

The FRAME SELECT button is used to display the top-most or root menu for the NCP. In some newer NCP models, the FRAME SELECT button has been re-labeled to “TOP MENU”.

4.1.2. Overview of the Display Line Selection Push-button Tools

Line-select push buttons allow the user to quickly select the frame, card, channel or parameter corresponding to that push-button. Any of the four lines displayed in the VFD is accessed by pressing the corresponding push-button to the right of the display. If the desired selection is not within the boundaries of the VFD, the rotary selector knob can be used to scroll up or down to the desired line and then the corresponding push-button is used to select and proceed to the next lower menu.

4.1.3. Overview of Rotary Control and Push-button Tool

The rotary selector knob can be used to scroll through the top level menus. To make a selection, simply position the cursor over the particular line and press the knob gently towards the unit. This action will allow you to proceed to the next lower menu or parameter setting stage.

Once in the parameter setting stages, rotation of the selector knob sets the value of that parameter. Pressing the knob (shaft encoder) sets the parameter value and returns the screen to the previous menu.

4.1.4. Overview of SETUP Push-Button

The **SETUP** pushbutton is used in conjunction with the menu and display pushbuttons. This allows the user to exit the current menu item and return to the previous level without saving any changes. The **SETUP** pushbutton is located to the lower-right of the rotary selector knob, below the **SELECT** pushbutton.

4.1.5. Overview of SELECT Push-Button

The main function of the **SELECT** pushbutton is used to save and send a particular parameter value displayed on screen. The **SELECT** pushbutton is located to the right of the rotary selector knob, above the **SETUP** pushbutton.

4.1.6. Overview of the PRESET CONFIGURATION Push-Buttons

Preset configuration push-buttons provide quick access to VistaLINK™-enabled frame/card parameters.

To set a Quick-Access Button from the panel:

1. Select a frame, card, parameter, service or configuration via the on-screen display menu and shaft-encoder
2. Press and hold the specific Quick-Access Preset Button for 3 seconds
3. Upon acceptance of setting, Quick-Access Preset Button's LED will flash for 5 seconds, then remain "on"
4. When selected during regular operation, the Preset Button will flash for 5 seconds and the VFD will show the quick-access parameter ready to be configured

Once a preset configuration has been attempted, but the selected button continues to flash, the corresponding hardware/frame could not be found by the NCP and subsequently no configuration through this selection is available. Attempt to run a single discovery cycle (see section 6) from the NCP to locate the frame/module. If flashing persists, contact Evertz service for further assistance.

4.1.7. Overview of SHIFT Push-Button

Using the **SHIFT** function in combination with the PRESET CONFIGURATION push-buttons allows the user to access other pre-configured access settings for an additional 8 inputs. If not selected, the SHIFT LED will remain off and the user can preset configuration buttons 1-8. When selected, the SHIFT LED will be on and allow the user to preset buttons 9-16.

4.1.8. Overview of the PANEL LOCK Push-Button

The **PANEL LOCK** pushbutton locks the current front panel setup of the 9000NCP. The panel lock function must be disabled in order to change any settings on the unit. An illuminated LED on the pushbutton indicates panel lock status. The panel lock pushbutton is the right-most push-button on the front panel.

5. 9000NCP2 NETWORK CONTROL PANEL

The display area consists of a 24 digit alphanumeric display, 8 preset configuration push-buttons, 4 line select push-buttons, tactile rotary with push-button selection and panel lock. The keypad can be used to select a specific frame, card or parameter being addressed by the NCP and is configurable by the user.

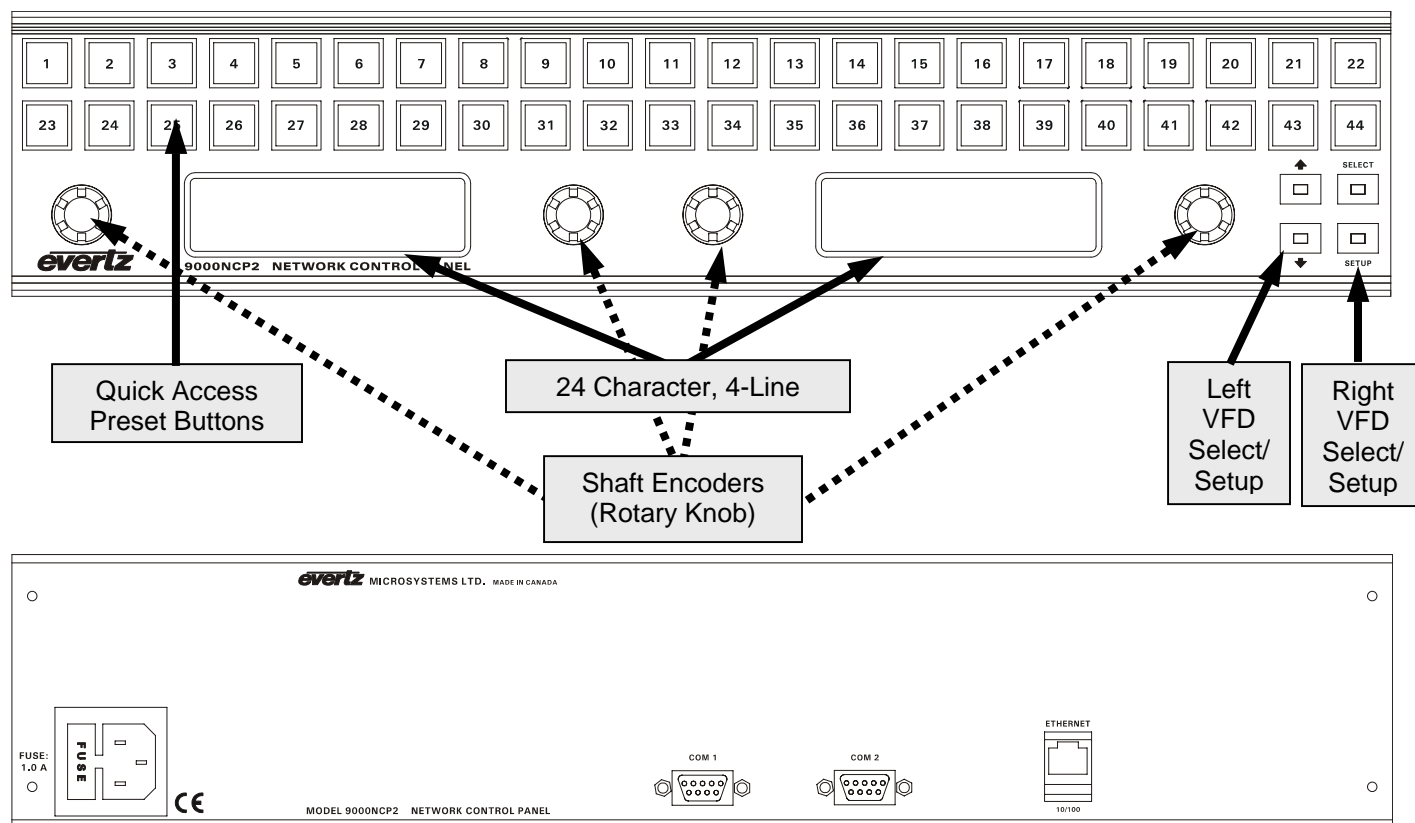

Figure 4: 9000NCP2 Front and Rear Views

5.1. 9000NCP2 FRONT PANEL OVERVIEW

5.1.1. Overview of the PRESET CONFIGURATION Push-Buttons

To set a Quick-Access Button from the panel:

1. Select a frame/card parameter via the on-screen display menu and shaft-encoder
2. Press and hold the specific Quick-Access Preset Button for 2 seconds
3. Upon acceptance of setting, Quick-Access Preset Button's LED will flash for 5 seconds, then remain "on"
4. When selected during regular operation, the Preset Button will flash for 5 seconds and the VFD will show the quick-access parameter ready to be configured

Once a preset configuration has been attempted, but the selected button continues to flash, the corresponding hardware/frame could not be found by the NCP and subsequently no configuration through this selection is available. Attempt to run a single discovery cycle (see section 6) from the NCP to locate the frame/module. If flashing persists, contact Evertz service for further assistance.

5.1.2. Overview of Rotary Control and Parameter Selection

The rotary selector knob is used to scroll through the menus. To make a selection, simply position the highlighted line over the frame, card or parameter and press the knob gently towards the unit. Similarly, the "Select" button for that particular VFD (Left or Right, see diagram) can also be used to make the selection. This action will allow you to proceed to the next lower menu or parameter setting stage.

Once in the parameter setting stages, rotation of the selector knob sets the value of that parameter. Pressing the knob (shaft encoder) sets the parameter value and returns the screen to the previous menu.

Split screen and dual rotary knob control is possible on the 9000NCP2. In this configuration, a particular parameter is selected by the right rotary knob, then transferred (by pressing and holding the right rotary knob for 5 seconds, then releasing) to the left for further configuration. The VFD automatically configures itself for split screen display, and the right rotary knob is now free to access a different parameter from those available. Left rotary knob parameter setting can only be performed by pressing the rotary knob into the unit (there are no "SETUP" and "SELECT" buttons). This is particularly useful when attempting to control multiple proc video and/or audio parameters for a single input channel.

5.1.3. Overview of SETUP Push-Button

The **SETUP** pushbutton is used in conjunction with the menu and display pushbuttons. This allows the user to exit the current menu item and return to the previous level without saving any changes. The **SETUP** pushbutton is located to the lower-right of the rotary selector knob, below the **SELECT** pushbutton.

5.1.4. Overview of SELECT Push-Button

The main function of the **SELECT** pushbutton is used to save and send a particular parameter value displayed on screen. The **SELECT** pushbutton is located to the right of the rotary selector knob, above the **SETUP** pushbutton.

6. 9000NCP AND 9000NCP2 CONFIGURAITON MENU

When power is applied to the unit, the 9000NCP provides a set-up menu with the following parameters. Once IP addresses have been correctly added, verified and saved, it is suggested that the user perform a “single” discovery cycle (see “Discovery” below) of the existing network to identify VistaLINK™-enabled frames and cards.

<back> - conveniently located at the start and end of a menu stack, this menu item allows the user to return to the previous menu for further configuration, if required.

Network setup – Set the IP address of the NCP unit, its subnet mask, gateway IP and Server IP (IP address of VistaLINK™ PRO Server) and DHCP¹. Once the Server IP address is set, a connection is made between the NCP and VistaLINK™ PRO Server, with the Server providing a full configuration update, including labels, masks and presets to that NCP unit. Once entered, **30 seconds are required for the changes to be stored in memory. Please do not power cycle the unit until after the 30 second window is expired.**

Configuration – If connected to a VistaLINK PRO server, this menu option lists all available configurations that can be selected and applied through the NCP. If there is no server connected, this menu option will not display any selectable options.

Service – If connected to a VistaLINK PRO server, this menu option lists all available services accessed through the NCP or NCP2 unit. This is a convenient tool allowing the user to make the menu selection through commonly used (user configured) service names instead of frames and module identification. If there is no server connected, this menu option will not display any selectable options.

Reboot – A menu option that allows the user a quick way to reboot the NCP/NCP2 unit without unplugging the AC power source from the unit. Options are “yes” and “cancel”.

Discovery – This parameter controls the auto-discovery cycle for the NCP unit. Set-up durations include: Off/Single/1 Minute/2 Minutes/5 Minutes/10/15/30/60 Minutes. Factory default discovery cycle is set to 30 minutes. More frequent discovery cycles add to network traffic, therefore, it is suggested that this NCP parameter is set to lower intervals for small networks and longer intervals (or even “Off”) for larger networks. Once entered, **30 seconds are required for the IP/DHCP changes to be stored in memory. Please do not power cycle the unit until after the 30 second window is expired.**

Manually added IP – Menu option to enable link to other frames that exist on other subnets and were not detected through the Discovery process.

Remove IP – Menu option to remove frames from the available list.

Request update – A menu option that allows the user to refresh the NCP menu options based on a forced discovery cycle.

¹ If running the NCP on a DHCP enabled network, set this parameter to “enable” for automatic IP address assignment. If not, select “disable”. (Factory default set to “enable”).

7. CONFIGURING NCP UNITS THROUGH VISTALINK™ PRO

The 9000NCP and 9000NCP2 control panels can also be configured through VistaLINK PRO as shown below.

Configuration options are separated into tabs, with the following descriptions:

Quick Access Buttons – Provide the user a simple GUI showing all configurable panel buttons with additional windows containing parameters, configurations and service which can then be assigned to these buttons.

Masking – This menu option limits which frames and/or products are accessible to a particular NCP unit from the available (discovered) list. This option is convenient for applications which only require specific NCP configuration access control to specific areas or services.

Hardware Configurations – From the available, preset “configurations” as shown on the “Configurations” branch of the network tree view, this menu option enables the NCP to select from an available list, which is then displayed on “Quick Access Buttons” page in the configuration window.

Services – Menu option to add service quick access from a previously generated service definition. The service is seen in the Service branch of the Navigation tree. If it is visible on this branch but is not available on this tab, this means that the service itself contains elements that are not configurable by this or any NCP unit.

Manually added IP – This menu option allows the user to add frame IP addresses from other equipment on a different subnet mask that may have not been detected through the NCP’s discovery cycle.

Server IP – This tab allows the user to link an NCP to a VistaLINK PRO server to share configuration information. If this item has been set through the NCP itself, the set IP address will be displayed in the specific field.

For further reference, screen shots with captions are provided on the subsequent pages.

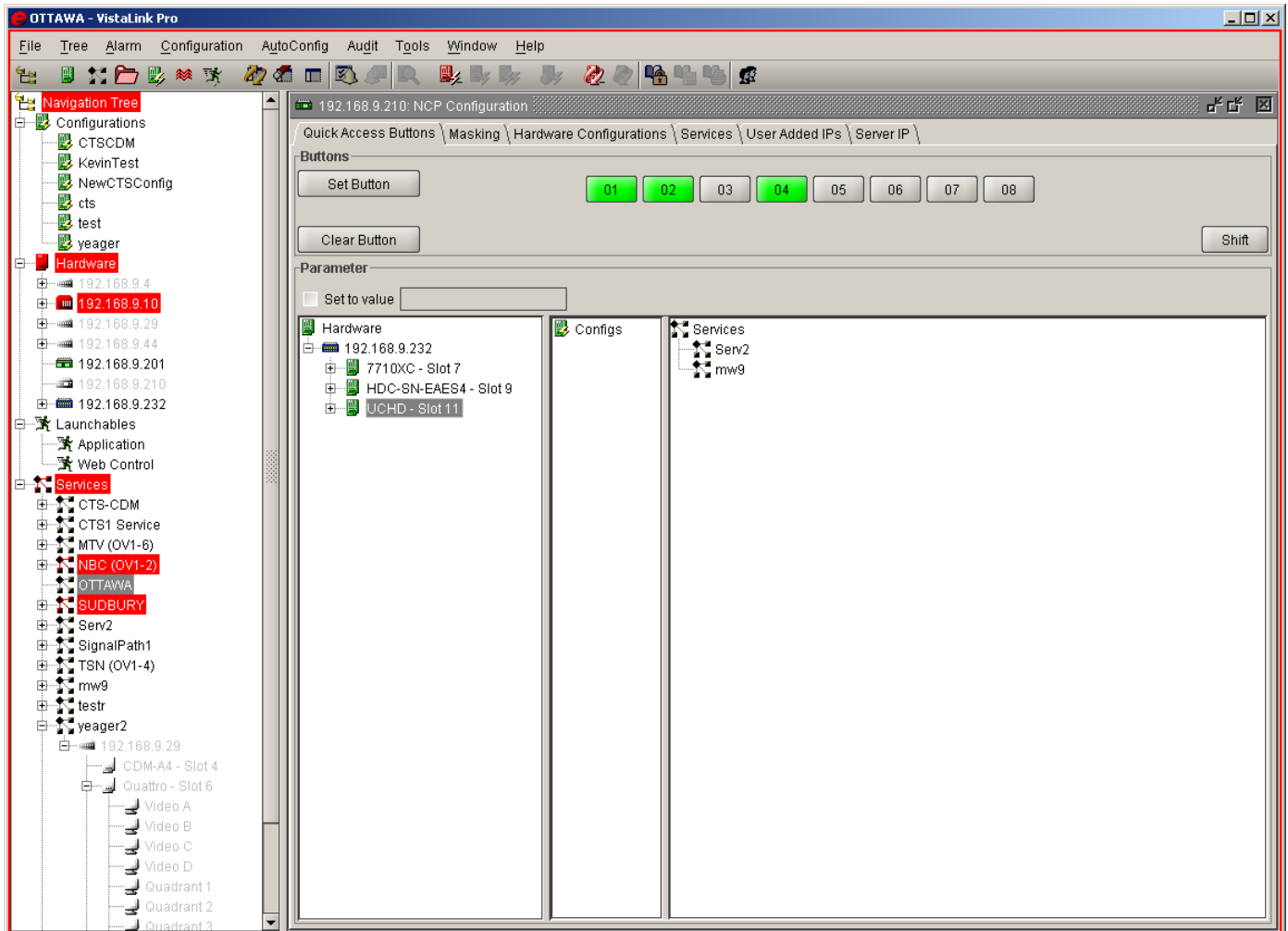

Figure 5: Quick Button Access Tab for 9000NCP

Quick button access screen for 9000NCP showing configured (green) and available (gray) preset buttons, SET and CLEAR button selection used to save or erase a preset, Shift key to access the next bank of 8 buttons, and 3 windows to select a hardware parameter, configuration or service. Configuration and Service settings are made through the “Hardware Configurations” and “Services” tabs respectively.

To SET a button, first select an unused button from the available list, identify the parameter, configuration or service, then click on “Set Button”. To CLEAR a button’s preset, select the button then click on “Clear Button”.

The “Set to Value” checkbox is used to set a particular parameter, then have a preset button assign that value whenever it is pressed. To set the value, expand the hardware tree view in the Hardware window, select the module and expand to the parameter level. Double-click on the parameter to show a list of available settings, select one. The “Set to Value” box will be checked and the set value will be shown in the adjacent field.

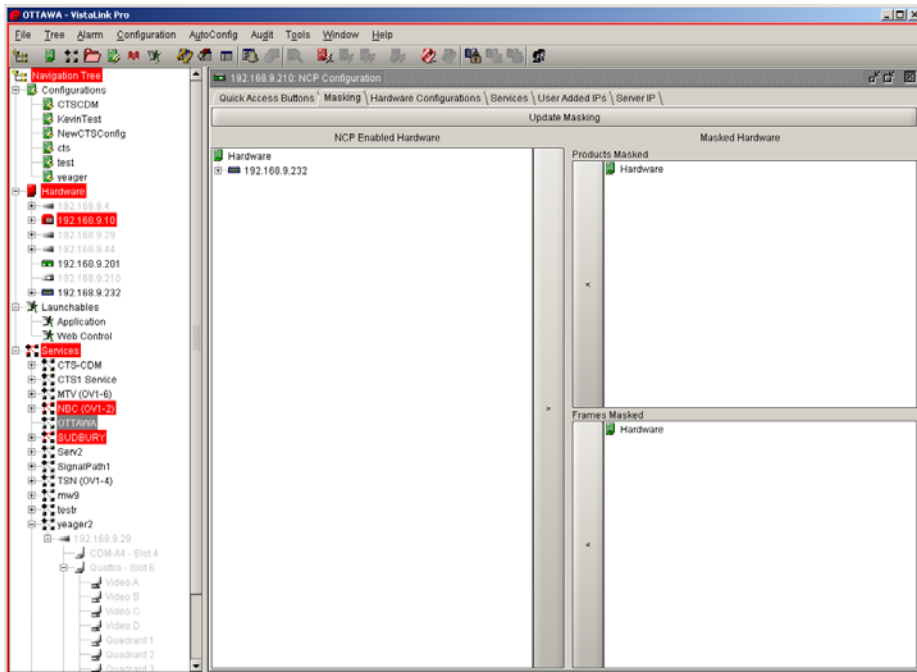

Figure 6: Masking Tab (Common to 9000NCP and 9000NCP2)

Select the frames and or module from the left window and then mask using the “>” button. The selected frame or module will appear in the appropriate window to the right. To re-enable this, select the frame or module, then “<”. To update the NCP, select the “Update...” button, underneath the tabs. If this selection is not made, configuration changes on the NCP will not take effect.

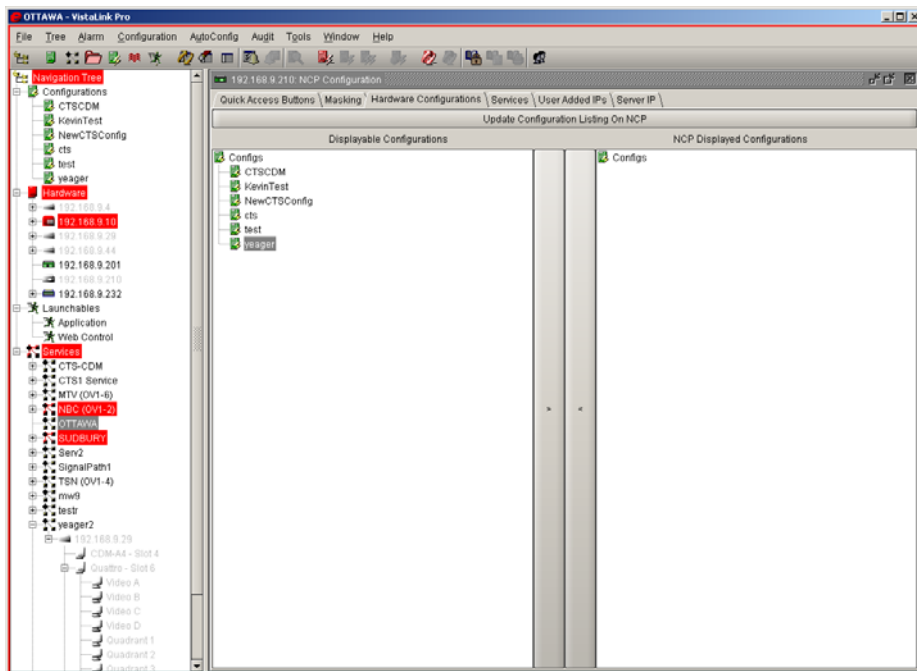

Figure 7: Hardware Configurations Tab (Common to 9000NCP and 9000NCP2)

Select the configurations from the available list and enable them for NCP configuration by clicking “>”. Remove them from the available list by selecting “<”. To update the NCP, select the “Update...” button, underneath the tabs. If this selection is not made, configuration changes on the NCP will not take effect.

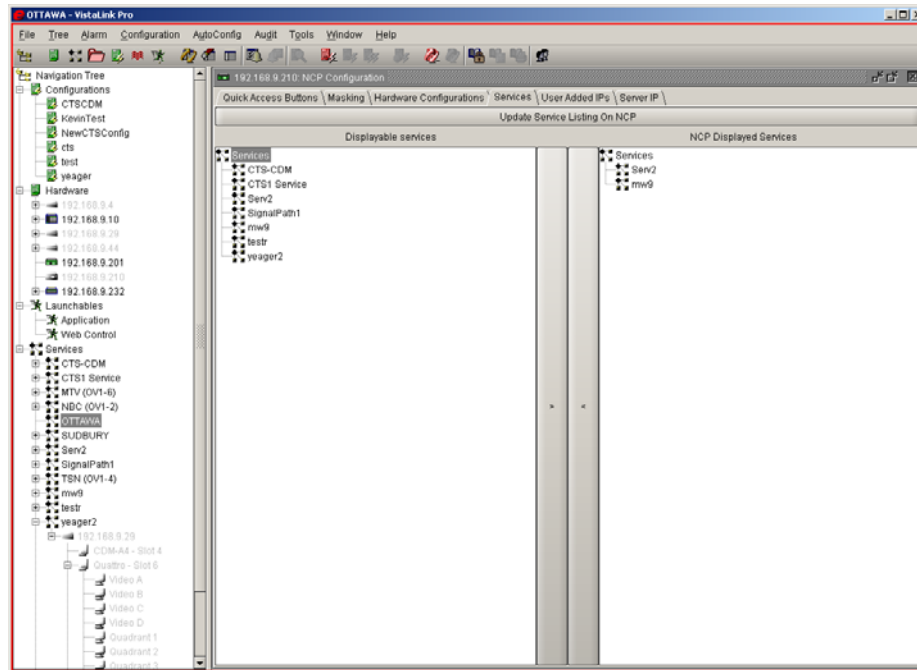

Figure 8: Services Tab (Common to 9000NCP and 9000NCP2)

Select services from the available list and enable them for NCP configuration by clicking “>”. Remove them from the available list by selecting “<”. To update the NCP, select the “Update...” button, underneath the tabs. If this selection is not made, configuration changes on the NCP will not take effect.

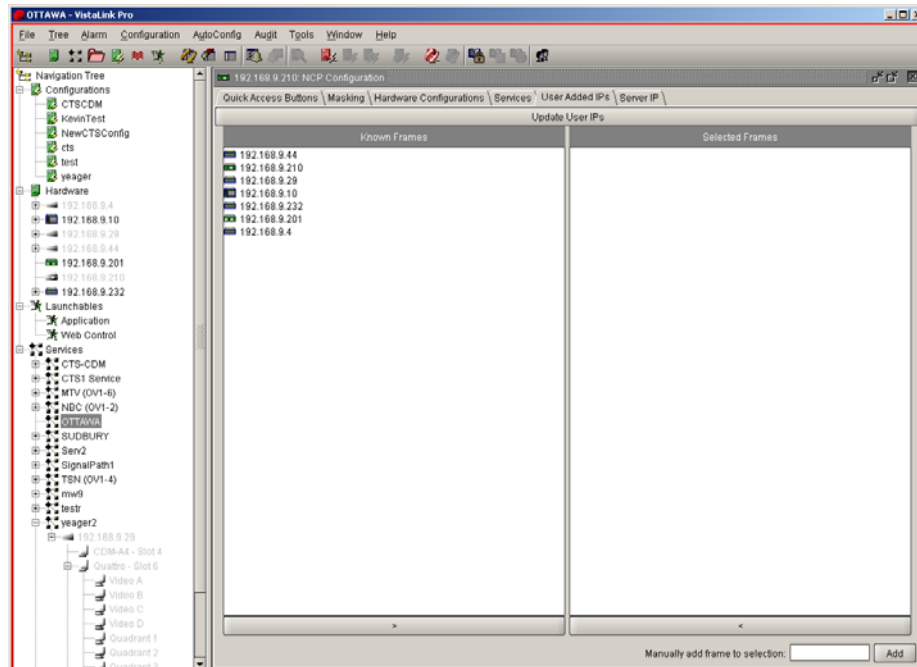

Figure 9: Manually Added IP Tab (Common to 9000NCP and 9000NCP2)

Select, add or remove IP addresses from this tab for NCP interfacing. To update the NCP, select the “Update...” button, underneath the tabs. If this selection is not made, configuration changes on the NCP will not take effect.

9000NCP/NCP2 VistaLINK(TM) Network Control Panel

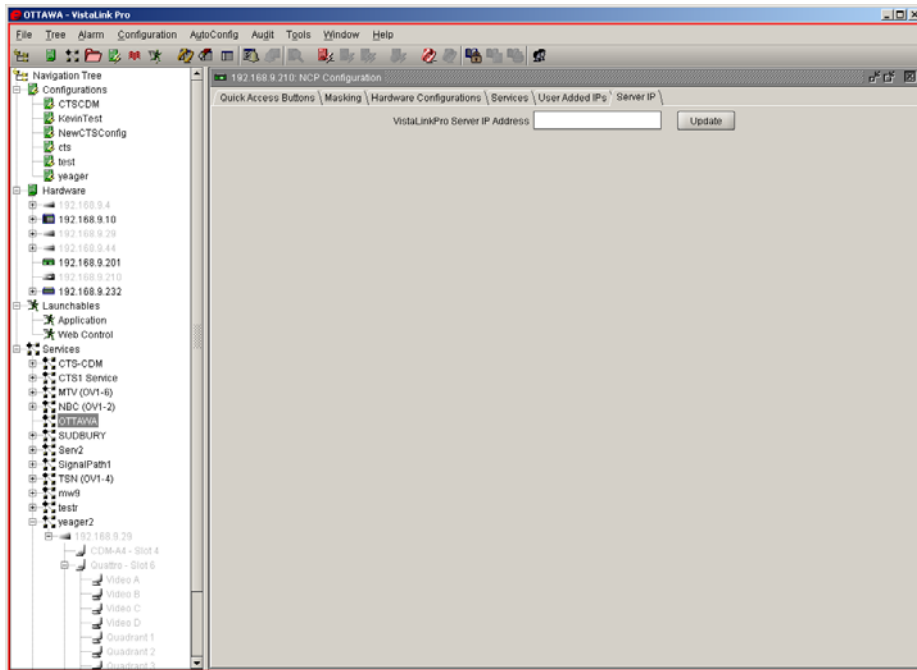

Figure 10: Server IP Tab (Common to 9000NCP and 9000NCP2)

Identify the Server that this particular NCP is to link with for configuration updates. To update the NCP, select the “Update...” button. If this selection is not made, configuration changes on the NCP will not take effect. If the Server IP was configured through the NCP unit itself, the IP address will appear in the field.

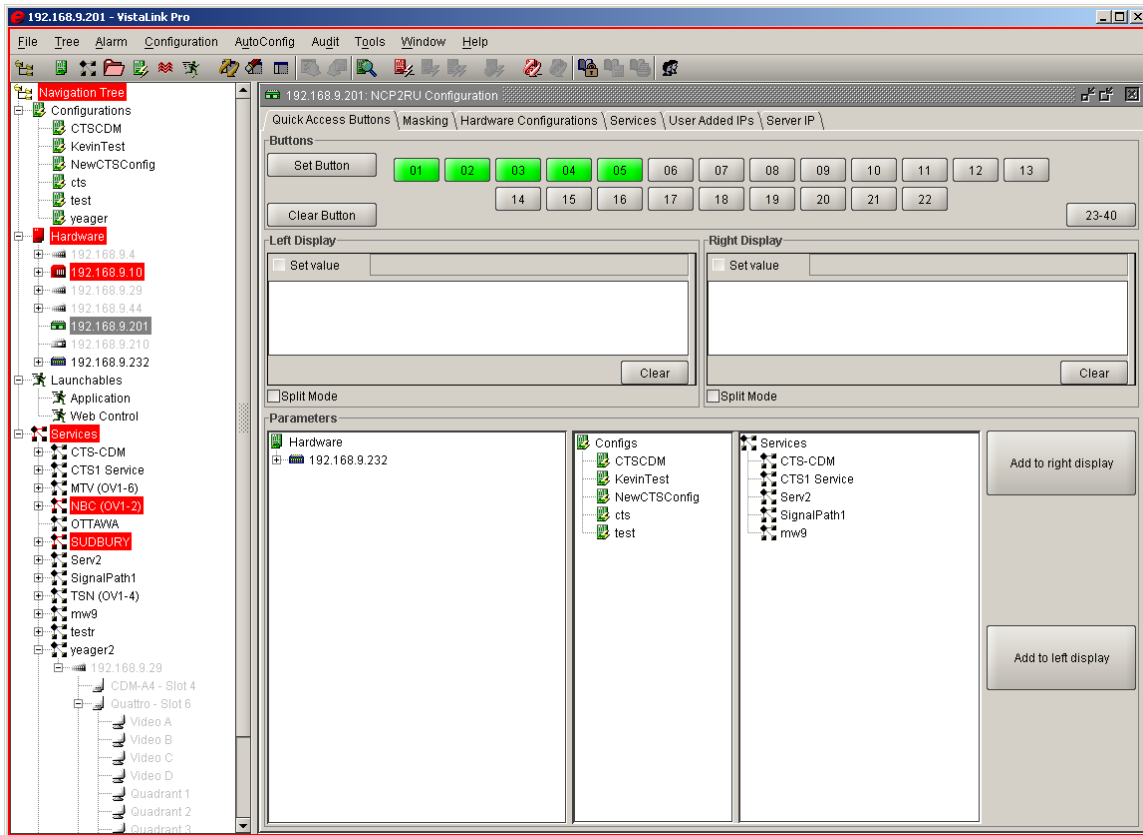

Figure 11: Quick Button Access Tab for 9000NCP2

Quick button access screen for 9000NCP2 showing configured (green) and available (gray) preset buttons, SET and CLEAR button selection used to save or erase a preset, Shift key to access the next bank of 22 buttons, and 3 windows to select a hardware parameter, configuration or service. Configuration and Service settings are made through the “Hardware Configurations” and “Services” tabs respectively.

To SET a button, first select an unused button from the available list, identify the parameter, configuration or service, then click on “Set Button”. To CLEAR a button’s preset, select the button then click on “Clear Button”.

The “Set to Value” checkbox is used to set a particular parameter, then have a preset button assign that value whenever it is pressed. To set the value, expand the hardware tree view in the Hardware window, select the module and expand to the parameter level. Double-click on the parameter to show a list of available settings, select one. The “Set to Value” box will be checked and the set value will be shown in the adjacent field.

The NCP2 has the additional feature of split screen mode. When selected for “split mode” via the checkbox, up to 4 parameter configurations can be set to the same preset button, as shown in the next figure.

9000NCP/NCP2 VistaLINK(TM) Network Control Panel

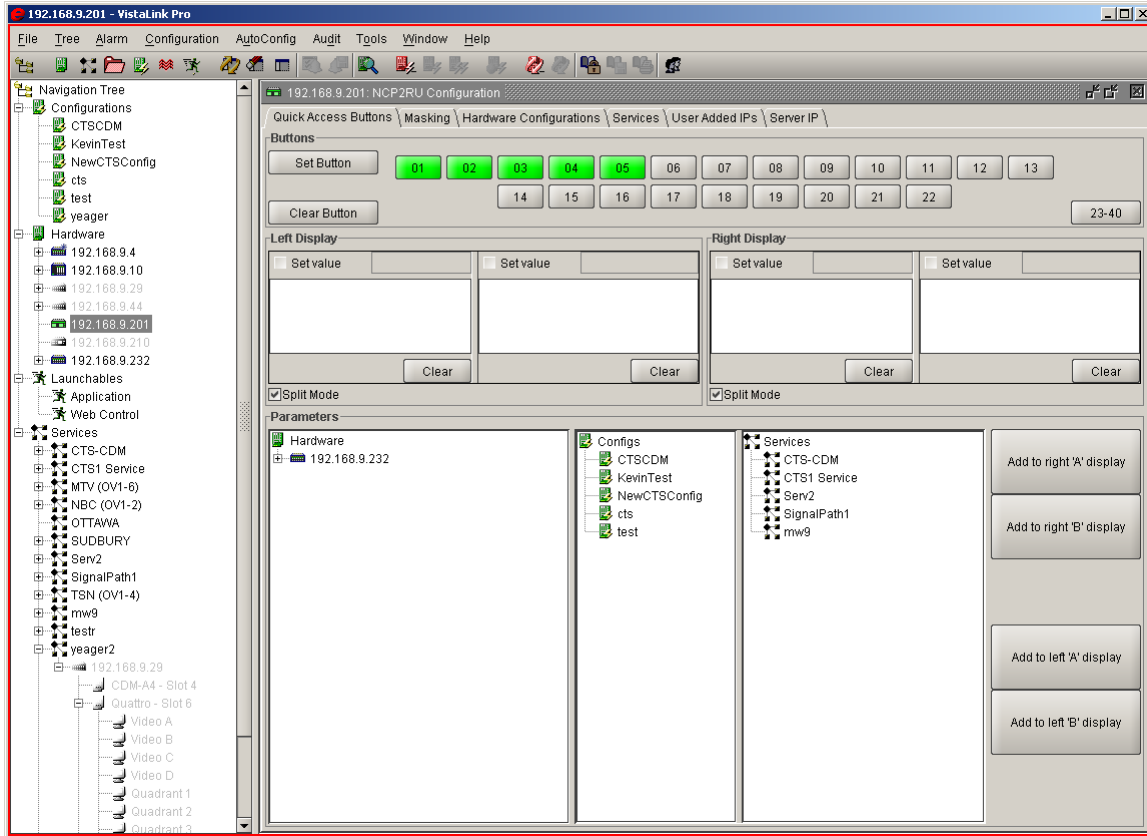

Figure 12: Quick Button Access Tab for 9000NCP2 in Split Mode

8. CONFIGURING VISTALINK™ ENABLED CARDS

In order to simplify the operation of the VistaLINK™-enabled modules, the operation from the 9000NCP network control panel has been limited to a subset of the enabled module menu system. Upon start-up, the 9000NCP or 9000NCP2 auto-discovers VistaLINK™-enabled frames and lists frames and associated cards on the alphanumeric display. The user can then use the rotary control to scroll through the available list of frames and push-select once the frame has been identified, or use one of four “line-select” push-buttons adjacent to the right of the display. Similarly, NCP/NCP2 accessible menu items are selected by either rotary or push-button control. For specific menu control items and descriptions see the module product manual for complete details.

On all menus, there is one extra selectable item: *Back*. Selecting *Back* through either the rotary knob (shaft encoder) or the pushbutton returns to the previous menu.

To adjust any parameter, use the rotary knob to set the specific parameter value, then press-in the rotary knob to complete the setting change. For simplicity, NCP/NCP2-controlled parameters and their ranges per VistaLINK™-enabled product are listed in tables below.

This NCP manual corresponds to the following releases: (consult www.evertz.com for the latest downloads.

NCP/NCP2 firmware	7700FC	VistaLINK PRO (including VLPRO-C)
2.04	1.14 build 1	7.1.3

8.1. 7710DCDA-HD AND 500DCDA-HD

Video Control	Input Video Type
	Video Standard
	Pulldown Reference
	A Frame Offset
	NTSC Colour Frame Offset
	H Filter Cutoff
	V Filter Cutoff
	Closed Captions
	VITC Generator
	VITC User Bits
	525 VITC Line
	625 VITC Line
Phase Offset	525 V Phase Offset
	525 H Phase Offset
	625 V Phase Offset
	625 H Phase Offset
Embedder	Audio De-embedder A Source
	Audio De-embedder B Source
	Audio Embedder A Group
	Audio Embedder B Group
Status	Input video type
	Input video standard
Video Output	Composite Display
	Composite Output Level
	Hue
	Saturation
	Contrast
	Brightness
	NTSC Setup
	Line 21 Setup
Picture Control	Aspect Ratio
	Loss of Video
	Panel Colours
	Status Window

Table 1: Overview of 7710DCDA-HD and 500DCDA-HD Menu

8.2. 7710UC-HD

Video			
	Offset		
		V Offset 1080i/59.94	0 to Max. lines
		H Offset 1080i/59.94	0 to Max. samples
		V Offset 1080i/50	0 to Max. lines
		H Offset 1080i/50	0 to Max. samples
		V Offset 720p/59.94	0 to Max. lines
		H Offset 720p/59.94	0 to Max. samples
		V Offset 480p/59.94	0 to Max. lines
		H Offset 480p/59.94	0 to Max. samples
	Misc.		
		Aspect Ratio	4:3 Side Panel 13:9 Stretch 14:9 Stretch 16:9 Stretch 13:9 Crop 14:9 Crop 16:9 Crop User defined
		Loss of Video	Black, Blue, Pass
		Panel Colors	Black, Blue, Red, White
		Output Video Standard	1080i/59.94 1080i/50 720p/59.94 480p/59.94
Video Input/Output			
	Input 525		
		H Start 525	The Input H Start and Input H Stop define the horizontal portion of the input image to process to the output. The range of values is 0 to 719 pixels and for the V is 0 to 484 for 525 input and 0-575 for 625 input.
		H Stop 525	
		V Start 525	
		V Stop 525	
	Input 625		
		H Start 625	The Input V Start and Input V Stop define the vertical portion of the input image to process to the output. The range of values is 0 to 484 for 525 input video and 0 to 575 for 625 input video.
		H Stop 625	
		V Start 625	
		V Stop 625	

9000NCP/NCP2 VistaLINK(TM) Network Control Panel

	Output Standard	H Start 1080i	
		H Stop 1080i	
		V Start 1080i	
		V Stop 1080i	
		H Start 720p	
		H Stop 720p	
		V Start 720p	
		V Stop 720p	
Video Deinterlacer			
	Deinterlacer		
		H Edge Enhancement	0 to 255
		V Edge Enhancement	0 to 255
		Motion Detection Threshold	0 to 15
		Interfield Weighting Factor	0 to 255
		Deinterlacer mode	Field or Frame
		Freeze Frame Threshold	0 to 31
		Noise Reduction Resolution	0 to 7
		Noise Reduction Level	0 to 31
		Detail Enhancement Resolution	0 to 5
		Detail Enhancement Level	0 to 31
		Edge Detection Threshold	0 to 15
	Cutoff		
		H Filter Cutoff	Soft Flat Enhanced
		V Filter Cutoff	Soft Flat Enhanced
Audio			
		De-embedder A	Group 1, Group 2, Group 3, Group 4
		De-embedder B	Group 1, Group 2, Group 3, Group 4
		Embedder A	Off, Follow A, Group 1, Group 2, Group 3, Group 4
		Embedder B	Off, Follow B, Group 1, Group 2, Group 3, Group 4

Table 2: Overview of 7710UC-HD Menu

8.3. 7710XC

Most parameters on the 7710XC module are NCP enabled. Consult the 7710XC product manual for an accurate listing of accessible parameters.

8.4. 7711HDC-X AND 7712HDC-X

Video Settings		
	Video Standard	0 - Auto 1 - 1080i/59.94 to 525i/59.94 2 - 720p/59.94 to 525i/59.94 3 - 1080i/50 to 625i/50 4 - 1080p/23.98sF to 525i/59.94 5 - 1080p/29.97sF to 525i/59.94 6 - 1080p/25sF to 625i/50 7 - 1035i/59.94 to 525i/59.94 8 - 480p/59.94 to 525i/59.94
	Output Level	-120 to 56
	Hue	-17.5 to 17.5
	Saturation	-10 to 10
	Contrast	0 to 20
	Brightness	-7.5 to 15.0
Phase		
	H Phase 525	0 to 1715
	H Phase 625	0 to 1727
	V Phase 525	0 to 524
	V Phase 625	0 to 624

Table 4: Overview of 7711HDC-x and 7712HDC-x Menu

8.5. 7720AM-AES4

AES	AES1 Mixer Input A-1	Ch1, Ch2, Ch3, Ch4, Ch5, Ch6, Ch7, Ch8, None
	AES1 Mixer Input A-2	Ch1, Ch2, Ch3, Ch4, Ch5, Ch6, Ch7, Ch8, None
	AES1 Mixer Input B-1	Ch1, Ch2, Ch3, Ch4, Ch5, Ch6, Ch7, Ch8, None
	AES1 Mixer Input B-2	Ch1, Ch2, Ch3, Ch4, Ch5, Ch6, Ch7, Ch8, None
	AES2 Mixer Input A-1	Ch1, Ch2, Ch3, Ch4, Ch5, Ch6, Ch7, Ch8, None
	AES2 Mixer Input A-2	Ch1, Ch2, Ch3, Ch4, Ch5, Ch6, Ch7, Ch8, None
	AES2 Mixer Input B-1	Ch1, Ch2, Ch3, Ch4, Ch5, Ch6, Ch7, Ch8, None
	AES2 Mixer Input B-2	Ch1, Ch2, Ch3, Ch4, Ch5, Ch6, Ch7, Ch8, None
	AES3 Mixer Input A-1	Ch1, Ch2, Ch3, Ch4, Ch5, Ch6, Ch7, Ch8, None
	AES3 Mixer Input A-2	Ch1, Ch2, Ch3, Ch4, Ch5, Ch6, Ch7, Ch8, None
	AES3 Mixer Input B-1	Ch1, Ch2, Ch3, Ch4, Ch5, Ch6, Ch7, Ch8, None
	AES3 Mixer Input B-2	Ch1, Ch2, Ch3, Ch4, Ch5, Ch6, Ch7, Ch8, None
	AES4 Mixer Input A-1	Ch1, Ch2, Ch3, Ch4, Ch5, Ch6, Ch7, Ch8, None
	AES4 Mixer Input A-2	Ch1, Ch2, Ch3, Ch4, Ch5, Ch6, Ch7, Ch8, None
	AES4 Mixer Input B-1	Ch1, Ch2, Ch3, Ch4, Ch5, Ch6, Ch7, Ch8, None
	AES4 Mixer Input B-2	Ch1, Ch2, Ch3, Ch4, Ch5, Ch6, Ch7, Ch8, None
	AES1 Lvl Adjust A-1	-12 to 12 dB
	AES1 Lvl Adjust A-2	-12 to 12 dB
	AES1 Lvl Adjust B-1	-12 to 12 dB
	AES1 Lvl Adjust B-2	-12 to 12 dB
	AES2 Lvl Adjust A-1	-12 to 12 dB
	AES2 Lvl Adjust A-2	-12 to 12 dB
	AES2 Lvl Adjust B-1	-12 to 12 dB
	AES2 Lvl Adjust B-2	-12 to 12 dB
	AES3 Lvl Adjust A-1	-12 to 12 dB
	AES3 Lvl Adjust A-2	-12 to 12 dB
	AES3 Lvl Adjust B-1	-12 to 12 dB
	AES3 Lvl Adjust B-2	-12 to 12 dB
	AES4 Lvl Adjust A-1	-12 to 12 dB
	AES4 Lvl Adjust A-2	-12 to 12 dB
	AES4 Lvl Adjust B-1	-12 to 12 dB
	AES4 Lvl Adjust B-1	-12 to 12 dB
Misc	Sample Rate Converter	Enabled, Bypassed
	Mixer Fade Rate	0 to 1000 ms
	Lock Preference	Free Run, Genlock Only, DARS Only
Delay	Channel 1	0 to 2540 ms
	Channel 2	0 to 2540 ms
	Channel 3	0 to 2540 ms
	Channel 4	0 to 2540 ms
	Channel 5	0 to 2540 ms
	Channel 6	0 to 2540 ms
	Channel 7	0 to 2540 ms
	Channel 8	0 to 2540 ms

Table 5: Overview of 7720AM-AES4 Menu

8.6. 7735AVC-LB

Video Processing			
	Video Settings		
		Output level	-89 to 87
		Hue	-17.5 to 17.5
		Saturation	-10 to 10
		Contrast	0 to 20
		Brightness	-7.5 to 15
	Horizontal Phase		
		525 H Phase	0 to 1715
		625 H Phase	0 to 1727
	Vertical Phase		
		525 V Phase	0 to 524
		625 V Phase	0 to 624
Audio Processing			
	Channels 1 and 2		
		Audio Swap	No, Yes
		Peak Analog	8 to 24 dBu
		Channel 1 Gain	-128 to 127
		Channel 2 Gain	-128 to 127
	Channels 3 and 4		
		Audio Swap	No, Yes
		Peak Analog	8 to 24 dBu
		Channel 3 Gain	-128 to 127
		Channel 4 Gain	-128 to 127

Table 6: Overview of 7735AVC-LB Menu

8.7. 7735CDM-X

Audio		
	Audio delay	-37ms to 5s (in 0.5ms increments)
	Channel 1 Gain	-20 to 20
	Channel 2 Gain	-20 to 20
	Channel 3 Gain	-20 to 20
	Channel 4 Gain	-20 to 20
	Audio swap 1-2	Pass, Swap, Mono1, Mono 2
	Audio swap 3-4	Pass, Swap, Mono 3, Mono 4
	Channel pair swap	No, yes
Video		
	H Phase 525	0 to 1715
	H Phase 625	0 to 1727
	V Phase 525	0 to 524
	V Phase 625	0 to 624
	Black lvl	-128 to 127
	Video lvl	-128 to 109
	Chroma lvl	-33 to 32
	Hue	-64 to 64

Table 7: Overview of 7735CDM-x Menu

8.8. 7735CEM-X

Audio			
	Channel 1		
		CH1 Processing	1, 2, 3, 4, 1&2, 3&4, Mute
		CH1 AES Gain	12dB to 24dB
		CH1 Analog level	-24dB to 24dB
	Channel 2		
		CH2 Processing	1, 2, 3, 4, 1&2, 3&4, Mute
		CH2 AES Gain	12dB to 24dB
		CH2 Analog level	-24dB to 24dB
	Channel 3		
		CH3 Processing	1, 2, 3, 4, 1&2, 3&4, Mute
		CH3 AES Gain	12dB to 24dB
		CH3 Analog level	-24dB to 24dB
	Channel 4		
		CH4 Processing	1, 2, 3, 4, 1&2, 3&4, Mute
		CH4 AES Gain	12dB to 24dB
		CH4 Analog level	-24dB to 24dB
	Audio source		Group 1, 2, 3, 4, AES
	Audio Delay		-37 ms to 5000 ms
Video			
	Video Settings		
		Video Standard	NTSC 525, PAL 625
		Loss of Video	Freeze, Black
		Genlock Source	None, Input Video, Reference In
		NTSC Color Phase	0, 1
		Pal-B Color Phase	0, 1, 2, 3
	Video Phase		
		Fine Phase 525	-128 to 127 ns
		Fine Phase 625	-128 to 127 ns
		H Phase 525	0 to 1715
		H Phase 625	0 to 1727
		V Phase 525	0 to 524
		V Phase 625	0 to 624
	Video Processing	NTSC Setup Pedestal	On, Off
		Line 21 Setup Pedestal	On, Off, Blank
		Composite Display Mode	Black and White, Color
		Video Level	90 to 110.5 IRE
		Hue	-17.5 to 17.5
		Saturation	-10 to 10
		Contrast	0 to 20
		Brightness	-7.5 to 15

Table 8: Overview of 7735CEM-X Menu

8.9. 7742DLY-HD AND 7743DLY-HD

Misc		
	Genlock settings	1080i/59 1080i/60 or 1080p/30sF 720p/59 720p/60 1080i/50 or 1080p/25sF 1080p/23 1080p/24sF
	Reference V phase	1 - 2749
	Reference H phase	1 - 2749
Delay		
	Video frames delay	0 - 97
	Video line delay	0 - 1124
	Video samples delay	0 - 2749

Table 9: Overview of 7742DLY-HD and 7743DLY-HD Menu

8.10. 7745FS-EAES4-HD+P AND 7746FS(-EAES4)-HD

Audio																													
	Sample Rate Converters	Enabled/Bypassed																											
	Audio Sync Source	AES Input/Deembedders																											
	Additional audio delay	0-7 frames, tied to video is option 8																											
	Deembedder 1	Group 1, 2, 3, 4																											
	Deembedder 2	Group 1, 2, 3, 4																											
	Embedder 1	Disable, Group 1, 2, 3, 4																											
	Embedder 2	Disable, Group 1, 2, 3, 4																											
	Channel 1 – 8 Gain	-24dB to 24dB																											
Video																													
	Video Delay	0 to 7 frames																											
	Black Level (IRE or %)	-7.3 to 7.3																											
	Y Video Level	-64 to 127																											
	Chroma Level	-64 to 127																											
	Video Format	1080p/23.98sF, 1080p/24sF, 1080i/50, 1080i/59.94, 480p/59.94, 1080i/60, 720p/59.94, 720p/60, 525, 625, AUTO																											
	V Phase <ul style="list-style-type: none"> • depends on the input standard selected from the “Video Format” menu. • Max. V delay is listed per input standard 	<table border="1"> <thead> <tr> <th></th> <th>Input Standard</th> <th>Max. V delay</th> </tr> </thead> <tbody> <tr> <td>0 to:</td> <td>1080p/23.98sF</td> <td>1125</td> </tr> <tr> <td></td> <td>1080p/24sF</td> <td>1125</td> </tr> <tr> <td></td> <td>1080i/50</td> <td>1125</td> </tr> <tr> <td></td> <td>1080i/59.94</td> <td>1125</td> </tr> <tr> <td></td> <td>480p/59.94</td> <td>N.A.</td> </tr> <tr> <td></td> <td>1080i/60</td> <td>1125</td> </tr> <tr> <td></td> <td>720p/59.94</td> <td>750</td> </tr> <tr> <td></td> <td>720p/60</td> <td>750</td> </tr> </tbody> </table>		Input Standard	Max. V delay	0 to:	1080p/23.98sF	1125		1080p/24sF	1125		1080i/50	1125		1080i/59.94	1125		480p/59.94	N.A.		1080i/60	1125		720p/59.94	750		720p/60	750
	Input Standard	Max. V delay																											
0 to:	1080p/23.98sF	1125																											
	1080p/24sF	1125																											
	1080i/50	1125																											
	1080i/59.94	1125																											
	480p/59.94	N.A.																											
	1080i/60	1125																											
	720p/59.94	750																											
	720p/60	750																											
	H Phase	<table border="1"> <thead> <tr> <th></th> <th>Input Standard</th> <th>Max. H delay</th> </tr> </thead> <tbody> <tr> <td></td> <td>1080p/23.98sF</td> <td>2750</td> </tr> <tr> <td></td> <td>1080p/24sF</td> <td>2750</td> </tr> <tr> <td></td> <td>1080i/50</td> <td>2640</td> </tr> <tr> <td></td> <td>1080i/59.94</td> <td>2200</td> </tr> <tr> <td></td> <td>480p/59.94</td> <td>not supported</td> </tr> <tr> <td></td> <td>1080i/60</td> <td>2200</td> </tr> <tr> <td></td> <td>720p/59.94</td> <td>1650</td> </tr> <tr> <td></td> <td>720p/60</td> <td>1650</td> </tr> </tbody> </table>		Input Standard	Max. H delay		1080p/23.98sF	2750		1080p/24sF	2750		1080i/50	2640		1080i/59.94	2200		480p/59.94	not supported		1080i/60	2200		720p/59.94	1650		720p/60	1650
	Input Standard	Max. H delay																											
	1080p/23.98sF	2750																											
	1080p/24sF	2750																											
	1080i/50	2640																											
	1080i/59.94	2200																											
	480p/59.94	not supported																											
	1080i/60	2200																											
	720p/59.94	1650																											
	720p/60	1650																											
	Freeze mode	Last field 1, last field 2, last frame, black																											

Table 10: Overview of 7745FS-EAES4-HD+P and 7746FS(-EAES4)-HD Menu

8.11. 7745FS-EAES+P

Video Processing			
	Horizontal Phase		
		525 H Phase	0 to 1715
		625 H Phase	0 to 1727
	Vertical Phase		
		525 V Phase	0 to 524
		625 V Phase	0 to 624
	Video Settings		
		Genlock Source	Reference In, Input video, None
		Black level	-128 to 127
		Y video level	-64 to 127
		Chroma level	-64 to 127
Audio Processing			
	Channel 1 Gain		-24 to 24 dB
	Channel 2 Gain		-24 to 24 dB
	Channel 3 Gain		-24 to 24 dB
	Channel 4 Gain		-24 to 24 dB

Table 11: Overview of 7745FS-EAES+P Menu

This page left intentionally blank