

User's Guide

3922 496 30691 August 2009 v5.0

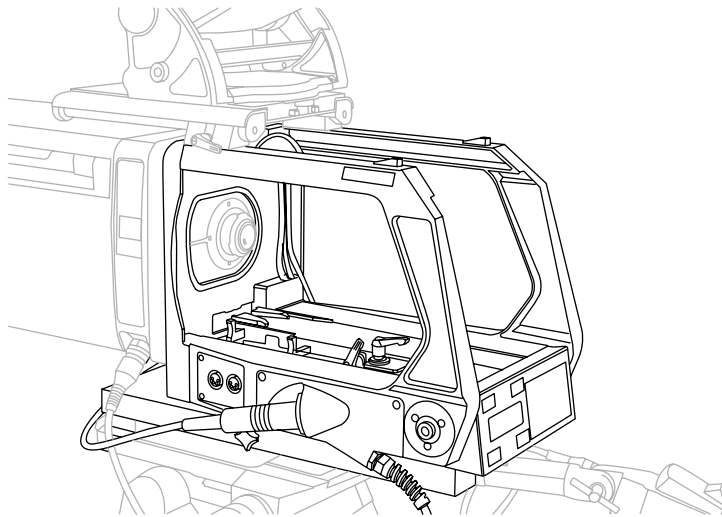

LDK 4488, LDK 4489

SuperXpander, Xpander

Declaration of Conformity

We, Grass Valley Nederland B.V., Kapittelweg 10, 4827 HG Breda, The Netherlands, declare under our sole responsibility that this product is in compliance with the following standards:

- EN60065 : Safety
- EN55103-1: EMC (Emission)
- EN55103-2: EMC (Immunity)

following the provisions of:

- a. the Low Voltage directive 2006/95/EC
- b. the EMC directive 2004/108/EC

FCC Class A Statement

This product generates, uses, and can radiate radio frequency energy and if not installed and used in accordance with the instructions, may cause interference to radio communications.

It has been tested and found to comply with the limits for a class A digital device pursuant to part 15 of the FCC rules, which are designed to provide reasonable protection against such interference when operated in a commercial environment.

Operation of this product in a residential area is likely to cause interference in which case the user at his own expense will be required to take whatever measures may be required to correct the interference.

Copyright

Copyright Grass Valley Nederland B.V. 2009. Copying of this document and giving it to others, and the use or communication of the contents thereof, are forbidden without express authority. Offenders are liable to the payment of damages. All rights are reserved in the event of the grant of a patent or the registration of a utility model or design. Liable to technical alterations in the course of further development.

Trademarks

Grass Valley and Infinity are trademarks of Grass Valley, Inc. All other tradenames referenced are service marks, trademarks, or registered trademarks of their respective companies.

Website

Visit the Grass Valley public website to download the latest user's guide updates and additional information about your broadcast product:

www.grassvalley.com

Table of contents

Chapter 1 – Introduction

1.1	System overview	15
1.2	Versions	16
1.3	Options and accessories	16

Chapter 2 – Installation

2.1	Minimum camera requirements	17
2.2	Mounting the viewfinder support	18
2.3	Exchanging the transmission module	19

Chapter 3 – Assembly

3.1	Assembly order	21
3.2	Tripod mounting	22
3.3	Mounting a lens	23
3.4	Mounting a camera	24
3.5	Transport position	26
3.6	Camera balance	26
3.7	Cable clamp	27
3.8	Mounting a scriptboard	27

Chapter 4 – Control panel

4.1	Buttons	29
4.2	LCD display panel controls	29
4.2.1	LCD display	30
4.2.2	Menu buttons	30
4.2.3	Prev/Next buttons	30
4.2.4	Item selectors	30
4.2.5	Plus/minus buttons	30
4.2.6	Menu function lists	31
4.3	Panel controls	33
4.3.1	Camera menu buttons	33
4.3.2	Indicators	33
4.3.3	Viewfinder control buttons	34
4.3.4	Intercom control buttons	34
4.3.5	Call switch	34

Chapter 5 – Power

5.1	Switching on power	35
5.2	Remote power mode	35
5.3	Local power mode	36
5.4	Utility power	37

Chapter 6 – Connectors

6.1	Left side view	39
6.1.1	Fixed utility power output (option)	40
6.1.2	Variable utility power output (option, SuperXpander only)	40
6.1.3	Lens interface connector	40
6.2	Right side view	41
6.2.1	Mains power supply input socket	42
6.2.2	Script light connector	42
6.2.3	Viewfinder component outputs (3x)	42
6.2.4	External CVBS output	42
6.2.5	Camera viewfinder connector	43
6.2.6	Top viewfinder connector (part of optional viewfinder support)	43

Chapter 7 – Specifications

7.1	Specifications for LDK 4488, LDK 4489	45
7.2	Dimensions	46

End-of-life product recycling

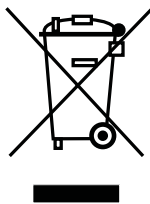

Grass Valley's innovation and excellence in product design also extends to the programs we've established to manage the recycling of our products. Grass Valley has developed a comprehensive end-of-life product take back program for recycle or disposal of end-of-life products. Our program meets the requirements of the European Union's WEEE Directive and in the United States from the Environmental Protection Agency, individual state or local agencies.

Grass Valley's end-of-life product take back program assures proper disposal by use of Best Available Technology. This program accepts any Grass Valley branded equipment. Upon request, a Certificate of Recycling or a Certificate of Destruction, depending on the ultimate disposition of the product, can be sent to the requester.

Grass Valley will be responsible for all costs associated with recycling and disposal, including freight, however you are responsible for the removal of the equipment from your facility and packing the equipment ready for pickup.

For further information on the Grass Valley product take back system please contact Grass Valley at + 800 80 80 20 20 or +33 1 48 25 20 20 from most other countries. In the US and Canada please call 800-547-8949 or 530-478-4148. Ask to be connected to the EH&S Department. In addition, information concerning the program can be found at:

www.thomsongrassvalley.com/environment

Important information

Read this information carefully before installing this equipment and retain them for future reference. Read and comply with the warning and caution notices that appear in the manual.

Any changes or modifications not expressly approved in this manual could void your authority to operate this equipment.

Safety Summary

This information is intended as a guide for trained and qualified personnel who are aware of the dangers involved in handling potentially hazardous electrical/electronic equipment. It is not intended to contain a complete list of all safety precautions which should be observed by personnel in using this or other electronic equipment.

The installation of this equipment involves risks both to personnel and equipment and must be performed only by qualified personnel exercising due care.

During installation and operation of this equipment, local building safety and fire protection standards must be observed.

Before connecting the equipment to the power supply of the installation, the proper functioning of the protective earth lead of the installation needs to be verified.

Whenever it is likely that safe operation is impaired, the apparatus must be made inoperative and secured against any unintended operation. The appropriate servicing authority must then be informed. For example, safety is likely to be impaired if the apparatus fails to perform the intended function or shows visible damage.

Warnings

Warnings indicate danger that requires correct procedures or practices to prevent death or injury to personnel.

- Do not modify this equipment;
- Installation of this equipment must only be performed by qualified personnel;
- Only mount the unit on a tripod or pedestal and head that can carry a payload of more than 50 kg;
- Grass Valley clearly states that it is unacceptable with respect to safety to use Triax cables (for the interconnection between Base Station and the SuperXpander/Xpander) with knowingly a short circuit between the inner and outer shield. Also the use of coax cables or the use of patch panels with a short circuit between the inner and outer shield is prohibited;
- Do not use any accessories other than those recommended by the manufacturer;
- In case of an emergency ensure that the power is disconnected;
- Mount equipment so that power lead can be accessed to disconnect power;
- Any interruption of the protection conductor inside or outside the apparatus, or disconnection of the protective earth terminal, is likely to make the apparatus dangerous. Intentional interruption is prohibited;
- Use only fuses of the type and rating specified;
- To prevent fire or shock hazard, do not expose the unit to rain or moisture.

-
- There are no user serviceable parts inside. Refer servicing to qualified personnel only or contact your local Grass Valley representative;
 - Observe local building safety, fire protection and electrical installation standards during installation and operation of this equipment;
 - Before connecting the equipment to the power supply of the installation, verify the proper functioning of the protective earth lead;
 - Whenever it is likely that safe operation is impaired, the apparatus must be made inoperative and secured against any unintended operation.

Cautions

Cautions indicate procedures or practices that should be followed to prevent damage or destruction to equipment or property.

- Do not subject the unit to severe shocks or vibration;
- Do not expose the unit to extremes of temperature;
- To prevent risk of overheating, ventilate the product correctly;
- Connect the product only to a power source with the specified voltage rating.

Wichtige Hinweise

Lesen Sie bitte diese Hinweise genau bevor Sie diese Apparatur installieren und erhalten Sie Sie für künftiges Nachslagen. Beachten und Lesen Sie alle mit "Achtung" und "Vorsicht" gekennzeichneten Warnhinweise.

Änderungen haben zur Folge, dass die Garantie ungültig wird und der Benutzer für etwaige durch die veränderte Ausrüstung verursachte Störungen haftbar gemacht werden könnte.

Sicherheit (Zusammenfassung)

Diese Informationen sind als Leitfaden für qualifiziertes Fachpersonal gedacht, das die Gefahren beim Umgang mit potenziell gefährlicher elektrischer/elektronischer Ausrüstung kennt. Es handelt sich dabei nicht um eine vollständige Zusammenstellung aller Sicherheitsvorkehrungen, die beim Gebrauch dieser oder anderer elektronischer Geräte zu beachten sind.

Die Montage, Wartung und Instandsetzung dieser Ausrüstung ist mit Risiken für Personal und Ausrüstung verbunden und darf nur von qualifiziertem Personal vorgenommen werden, wobei mit der nötigen Sorgfalt vorzugehen ist.

Beim Einbau und Betrieb dieser Ausrüstung müssen die örtlichen Gebäudesicherheits- und Brandschutzvorschriften beachtet werden. Vor dem Anschluss der Ausrüstung an die Stromversorgung der Anlage muss überprüft werden, ob der Schutzleiter intakt ist.

Wenn eine Beeinträchtigung des sicheren Betriebs wahrscheinlich ist, muss das Gerät außer Betrieb gesetzt und gegen ungewollten Betrieb gesichert werden. Dann muss der zuständige Kundendienst benachrichtigt werden. Eine Beeinträchtigung der Sicherheit ist zum Beispiel dann wahrscheinlich, wenn das Gerät nicht wie vorgesehen funktioniert oder einen sichtbaren Schaden aufweist.

Vorsicht

Mit "Vorsicht" wird auf eine Gefahr hingewiesen, die korrekte Arbeits- oder Verfahrensweisen erfordert, um Tod oder Verletzung zu verhindern.

- An dieser Ausrüstung dürfen keine Änderungen vorgenommen werden;
- Die Montage dieser Ausrüstung darf nur von Fachpersonal vorgenommen werden;
- Diese Ausrüstung soll nur auf einem Stativ oder Sockel und einem Kopf aufgestellt werden die eine Last von mehr als 50 kg tragen kann;
- Grass Valley erklärt daß es im Zusammenhang mit der Sicherheit nicht gestattet ist Triaxkabel zu verwenden (für die Verbindung zwischen Base Station und SuperXpander/Xpander) die wissentlich ein Kurzschluß zwischen der innere und aussere Abschirmung haben. Auch die Verwendung von Koaxialkabel oder Rangierfeldern mit einem Kurzschluß zwischen der innere und aussere Abschirmung is nicht gestattet.
- Es sollen nur von den Hersteller empfohlene Zubehöre verwendet werden;
- Bei Eintreten eines Notfalls unbedingt die Stromzufuhr abschalten;
- Ausrüstung so montieren, daß das Netzkabel zum Abschalten der Stromzufuhr zugänglich ist;
- Jede Unterbrechung des Schutzleiters innerhalb oder ausserhalb des Geräts oder Trennung der Schutzleiter-anchlussklemme Könnte das Gerät fegefährlich machen. Eine absichtliche Unterbrechung ist untersagt;

-
- Es dürfen nur Sicherungen des vorgeschriebenen Typs und Nennwerts verwendet werden;
 - Um Feuer oder Schlaggefahr vorzubeugen, soll das Produkt nie an Regen oder Feucht ausgesetzt werden.
 - Dieses Produkt enthält keine Anwenderteile. Reparatur und Wartung nur von qualifiziertem Fachpersonal vornehmen lassen oder nehmen Sie Kontakt auf mit Ihrem Grass Valley Vertretene;
 - Beim Einbau und Betrieb dieser Ausrüstung müssen die örtlichen Gebäudesicherheits- und Brandschutzvorschriften beachtet werden;
 - Vor dem Anschluss der Ausrüstung an die Stromversorgung der Anlage muss überprüft werden, ob der Schutzleiter intakt ist;
 - Wenn eine Beeinträchtigung des sicheren Betriebs wahrscheinlich ist, muss das Gerät außer Betrieb gesetzt und gegen ungewollten Betrieb gesichert werden.

Achtung

Mit "Achtung" werden Arbeitsanweisungen gekennzeichnet, die zu befolgen sind, um eine Beschädigung oder Zerstörung der Ausrüstung bzw. von Eigentum zu verhindern.

- Dieses Produkt darf nicht an extremen Stöße oder Zittern ausgesetzt werden;
- Dieses Produkt darf nicht an extremen Temperaturen ausgesetzt werden;
- Um einer Überhitzungsgefahr vorzubeugen, ist das Produkt korrekt zu belüften;
- Das Produkt darf nur an eine Stromquelle mit der vorgeschriebenen Nennspannung angeschlossen werden.

Installation notices

For proper installation the following NEC articles should be noticed:

- Installation of equipment (NEC article 800.18);
- Avoid contact with conductors of other systems (NEC article 810.13);
- Provide extensive, separate clearance requirements for indoor and outdoor locations (NEC article 810.18).

Tripod installation

The typical configuration for this device (SuperXpander with Triax cables and 7-inch viewfinder mounted) has proved to be stable when used on a tripod with the following specifications: weight 24 kg, height 120 cm, leg distance (at floor level) of 135 cm.

Note that these values are recommendations only. Always check the mechanical stability of the device before using it.

Mains power supply chord

A mains power supply chord is not shipped with the device. To connect the device to the mains the following power supply cord is advised: type H03 VV-F or H03 VVH2-F flexible wire: 1 mm², 250V / 10A minimum or 16 AWG.

When the device is installed in one of the following countries the power chord must be compliant to the indicated specifications and regulations below.

Denmark

Supply cord of single-phase equipment having a rated current not exceeding 10A shall be provided with a plug according to the Heavy Current Regulations section 107-2-D1. Class I equipment provided with socket-outlets with earth contact or which are intended to be used in locations where protection against indirect contact is required according to the wiring rules shall be provided with a plug in accordance with standard sheet DK 2-1a or DK 2-5a.

Ireland

Apparatus which is fitted with a flexible cable or cord and is designed to be connected to a mains socket conforming to I.S. 411 by means of that flexible cable or cord and plug, shall be fitted with a 13A plug in accordance with Statutory Instrument 525:1997 - National Standards Authority of Ireland (section 28) (13A plugs and Conversion Adaptors for Domestic Use) Regulations, 1997.

Spain

Supply cords of single-phase equipment having a rated current not exceeding:

- 10A shall be provided with a plug according to UNE 20315:1994

CLASS I EQUIPMENT provided with socket-outlets with earth contacts, or which are intended to be used in locations where protection against indirect contact is required according to the wiring rules, shall be provided with a plug in accordance with UNE 20315:1994

Switzerland

Supply cords of equipment having a rated current not exceeding 10A shall be provided with a plug complying with SEV 1011 or IEC 884-1 and the following dimension sheet:

- SEV 6534-2.1991 Plug Type 12: L+N+PE250V 10A

UK

Apparatus which is fitted with a flexible cable or a cord and is designed to be connected to a mains socket conforming to BS 1363 by means of that flexible cable or cord and plug, shall be fitted with a "standard plug" in accordance with Statutory Instrument 1786: 1994 - The Plugs and Sockets etc. (Safety) Regulations 1994, unless exempted by those regulations.

Note: "Standard plug" is defined in SI 1786:1994 and essentially means an approved plug conforming to BS 1363 or an approved conversion plug.

US

Listed, detachable, maximum 4.5 m (14.76 ft.) long; rated minimum 125V, 10A, type SJT or type SVT flexible cord; one end terminates in NEMA 5-15P or 5-20P grounding-type attachment plug, other end in appliance coupler.

- Listed, detachable, maximum 4.5 m (14.76 ft.) long; rated minimum 250V, 10A, type SJT or type SVT flexible cord; one end terminates in NEMA 6-15P or NEMA 6-20P grounding-type attachment plug, other end in appliance coupler.

Fiber-optic transmission units



Laser safety statement (Europe)

Fiber-optic transmission units are classified as a "CLASS 1 Laser Product" according to EN 60825-1, Safety of Laser products. Class 1 laser products are considered safe and do not result in biological hazard if used according to the instructions.

Laser safety statement (US)

Fiber-optic transmission units are classified as a "CLASS 1 Laser Product" according to 21CFR 1040.10 of the US Food and Drug Administration (FDA) Center for Devices and Radiological Health.



WARNING

Use of controls, adjustments or performance of procedures other than those specified herein may result in hazardous radiation exposure.

To ensure proper use of this product, please read this user's guide carefully and retain it for future reference. Should the unit ever require maintenance, contact an authorized service location.

Fiber-optic cable precautions

Fiber-optic cables and connectors are easily damaged; take the following precautions into account:

- Do not bend the cable beyond the minimum permissible bend range specified for the cable.
- Avoid kinks in the cable.
- Avoid subjecting the cable to a high tension force (even momentarily).
- Do not twist the cable when connecting it to equipment.
- Insert connectors straight and fully into their corresponding sockets.
- In fiber-optic cable systems always put the dust caps on cable and panel connectors immediately after disconnecting a cable. Keep the dust caps clean.



Note

This Class 1 Laser Product may only be used with other Class 1 classified products such as the Grass Valley fiber base stations or LDK cameras equipped with Fiber adapters.

Cleaning fiber-optic connectors



WARNING

Always switch off power before cleaning the connectors.



WARNING

Never clean an optical connector attached to a fiber that is carrying light.

Particles of foreign matter on the tip of a ferrule can have a disabling effect on fiber-optic transmission. Fiber-optic connectors need to be cleaned every time they are mated and unmated; it is essential that fiber-optic users develop the necessary discipline to always clean the connectors before they are mated.

Use a commercially available cleaning kit specifically designed for fiber-optic connectors and follow the manufacturer's instructions carefully.

- The connector sections to be cleaned include the tips and sides of ferrules, the interior walls of alignment sleeves, and the interior and exterior of connector shells.
- For plugs, the interior surfaces of alignment sleeves and the tips of ferrules are to be cleaned with a cleaning stick treated with the appropriate fluid. (Cleaning sticks with a slender design are available that allow alignment sleeves to be cleaned without having to detach them.)
- For jacks, it is important to clean both the tips and sides of the completely protruding ferrules.
- Both the male and female connector shells tend to attract dust and metal particles, so it is important to clean both the insides and outsides.
- The fiber end face and ferrule must be absolutely clean before it is inserted into a transmitter or receiver.
- Mate the connector immediately! Don't let the connector lie around and collect dust before mating.
- Air can be used to remove lint or loose dust from the port of a transmitter or receiver to be mated with the connector. Never insert any liquid into the ports.



Chapter 1

Introduction

1.1 System overview

Grass Valley™ products from Thomson offer production professionals the most comprehensive multi-format solutions for acquisition, production, storage, and playback, and a strong foundation for centralized, proactive status and activity monitoring.

The Grass Valley SuperXpander/Xpander is such a solution. Compatible with most LDK camera* families, it supports box-type lenses, teleprompters and high-resolution viewfinders.

For sports and events coverage the use of large zoom lenses is a common requirement. The SuperXpander/Xpander acts as a large lens adapter, rapidly converting a portable Triax or fiber camera into a mobile production system. The modular transmission unit allows you to change from Triax to fiber configurations, even in the field.

To make life even easier, your camera can remain mounted in the SuperXpander/Xpander housing for transport, saving rigging time and precious space, and ensuring that the camera is aligned and ready to go immediately. Alternatively, you can mount or release the camera from the housing quickly so you can switch between pedestal, box lens, and handheld applications working with an EFP-style lens – even during a live program.

For fast-moving sports and entertainment television, camera operators demand a large, bright, high-resolution viewfinder. The SuperXpander/Xpander system incorporates a new 7" monochrome viewfinder providing unprecedented degrees of freedom. The unique design of the SuperXpander/Xpander system puts even a large viewfinder close to the optical axis of the camera, making camera movements and positioning more intuitive for the operator to ensure that the shot is right every time.

Secure connectors for intercom, prompt feed and other accessories are located on the base. The SuperXpander/Xpander also provides secure mounting and balancing for the largest prompt head.

*) Refer to the minimum camera requirements in the installation chapter.

1.2 Versions

Two versions of the SuperXpander/Xpander are available:

- The LDK 4489 Xpander supports box-type lenses and features mounting capability for a Grass Valley 7-inch viewfinder.
- The LDK 4488 SuperXpander has all Xpander functionality but it also features a control panel at its rear, putting operational adjustments under the hand of the operator.

1.3 Options and accessories

Triax transmission modules

with Fischer connector	LDK 4487/01
with ARD connector	LDK 4487/06
with Lemo (4E) connector	LDK 4487/11
with Lemo (3T) connector	LDK 4487/16
with Lemo (BBC) connector	LDK 4487/41
with Tri-Lock connector	LDK 4487/51

Fiber transmission modules

with Lemo connector	LDK 4487/61
with Stratos connector	LDK 4487/71
with SM connector	LDK 4487/81
with Fischer connector	LDK 4487/91

Power and control units

Utility power unit	LDK 4486
Control panel (option for the LDK 4489 Xpander)	LDK 4484

Other

Transport case for SXP	LDK 6986/01
Scriptboard with top light	LDK 6985/01

Chapter 2

Installation

2.1 Minimum camera requirements

Before installing the SuperXpander/Xpander, check the camera model compatibility and minimum software status as indicated in the table below.:

Supported camera type(s)	Required software status
LDK 100, 200, 300, 400, 500 (SD) cameras	Status 16 or higher
LDK 4000 camera	Status 3 or higher
LDK 5000 HD-prepared camera	Status 9 or higher
LDK 6000 HD camera	Status 28 or higher
LDK 6200 HD high speed camera	Status 6 or higher
LDK 8000 HD camera	Status 2 or higher
LDK 8300 HD high speed camera	no minimal status
LDK 4000 Elite HD camera	no minimal status
LDK 8000 Elite HD camera	no minimal status



Note

If the software of your camera needs to be updated to meet the requirements, please contact your local Grassvalley representative.

2.2 Mounting the viewfinder support

To mount the LDK 4020, LDK 4021 or LDK 4025 viewfinder on top of the SuperXpander/Xpander you need to install the viewfinder support that was supplied with the viewfinder.

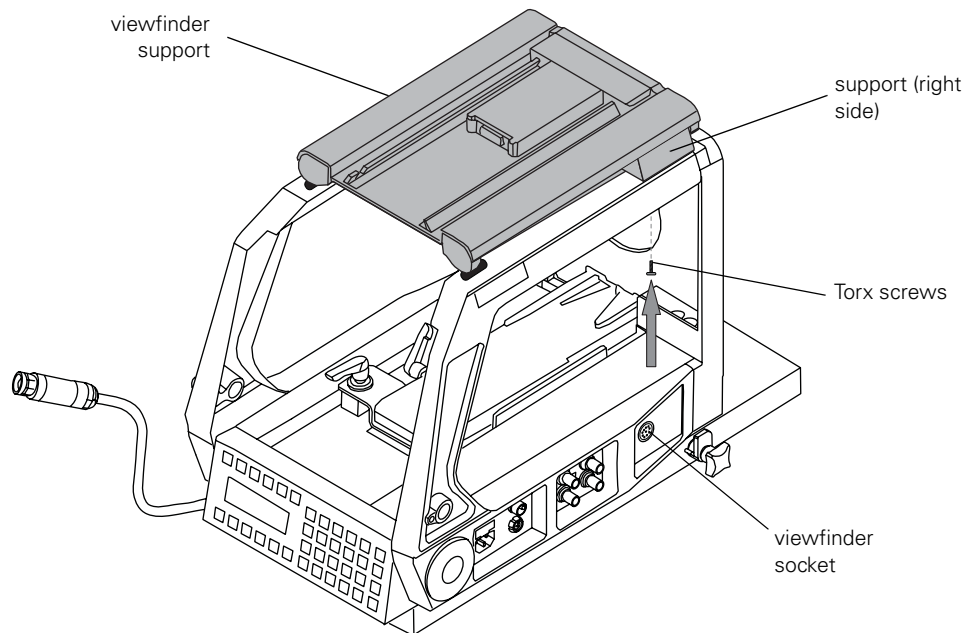

Mounting procedure

1. Remove the camera if it is already mounted.
2. Place the viewfinder support on top of the SuperXpander/Xpander and align the pins in the left and right supports with the holes in the SuperXpander.
3. Make sure that the support is aligned properly.
4. Using the four Torx screws supplied, secure the viewfinder support to the SuperXpander/Xpander (reach inside the unit and secure from underneath).
5. Attach the viewfinder support connector to the socket at the right front side.
6. Use the two internal cable clamps to guide the cable along the inside of the SuperXpander/Xpander.

2.3 Exchanging the transmission module

The SuperXpander/Xpander is supplied with either a Triax or a Fiber transmission module, depending on the base station and camera connector type you are using. You can exchange the transmission module easily to use the SuperXpander/Xpander with a different transmission system or connector type. To exchange the transmission module proceed as follows:



Caution

Make sure that power is switched off and both the mains power lead and the Triax or Fiber cable are disconnected from the SuperXpander/Xpander.

1. At the left side of the SuperXpander/Xpander locate the currently installed transmission module.
2. Unplug the flying lead from the camera adapter side.
3. Unscrew the four captive screws of the transmission module using a Torx-10 screwdriver.

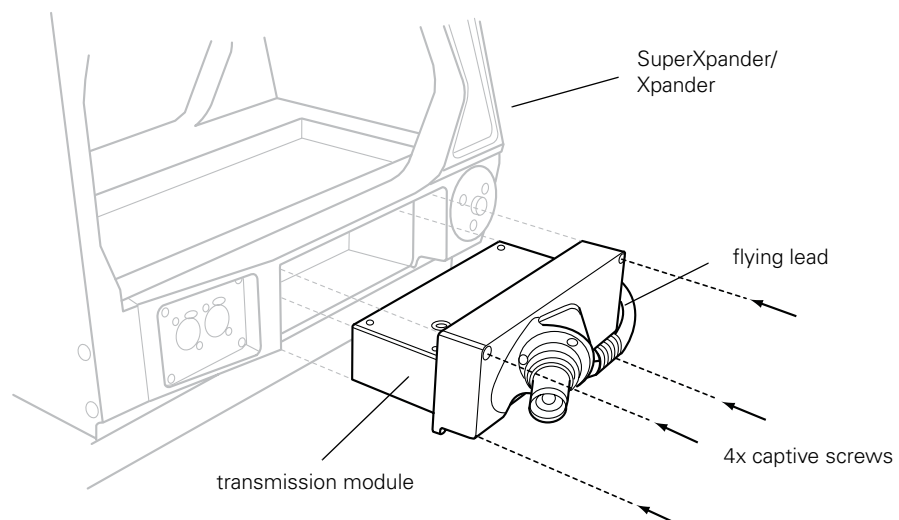

4. Pull the transmission module out of its bay. Note that the flying lead is attached to the module. Store the module at a safe place. The module can also be stored in the optional LDK 6986/01 Transport case.
5. Insert the new transmission module into the empty bay and slide it in until the front of the module is aligned with the outside of the SuperXpander/Xpander.
6. Secure the transmission module using the four captive screws.
7. Plug the flying lead into the camera adapter.



Note

Local power mode is not fully supported when using the SuperXpander/Xpander in a Fiber configuration. Refer to the chapter ["Power" on page 35](#).

Chapter 3

Assembly

3.1 Assembly order

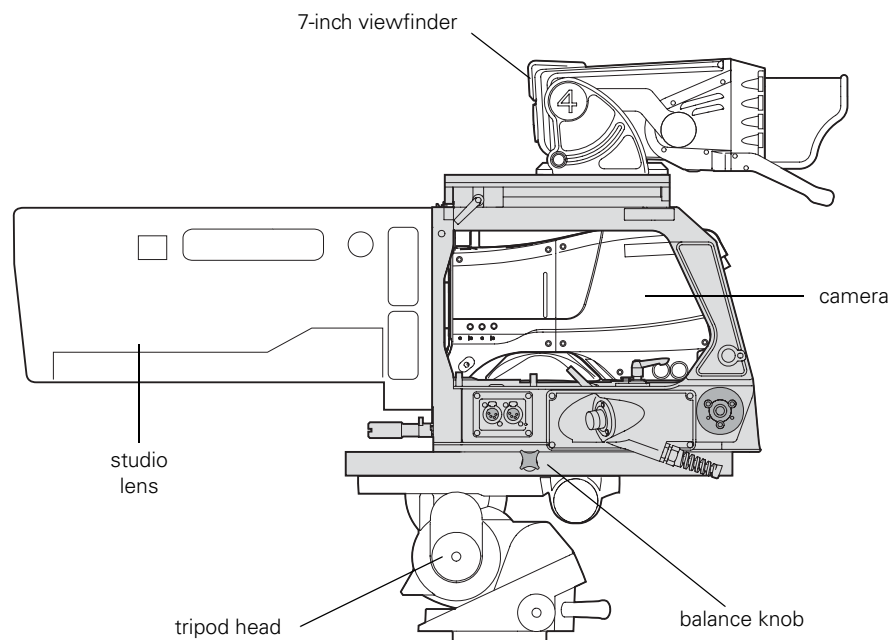

It is important that you assemble and disassemble the units in the right order. The correct order of assembly is as follows:

1. Attach the SuperXpander/Xpander to the tripod.
2. Mount the lens onto the SuperXpander/Xpander.
3. Attach the camera to the SuperXpander/Xpander.
4. Mount the viewfinder onto the viewfinder support of the SuperXpander/Xpander

3.2 Tripod mounting



Caution

Only mount the unit on a tripod or pedestal and head that can carry a load of more than 50 kg.

To mount the SuperXpander/Xpander on a tripod, first attach the tripod wedge plate to the underside of the SuperXpander/Xpander as follows:

1. Lay the SuperXpander/Xpander on its side.
2. Fasten the balance knob tightly.
3. Ensure that the flat side of the tripod wedge plate is against the underside of the SuperXpander/Xpander.
4. Secure the tripod wedge plate to the SuperXpander/Xpander by screwing four M6 x 16 screws into the holes provided.
5. Slide the SuperXpander/Xpander onto the tripod and lock in place with the tripod locking bar and security pin.

3.3 Mounting a lens

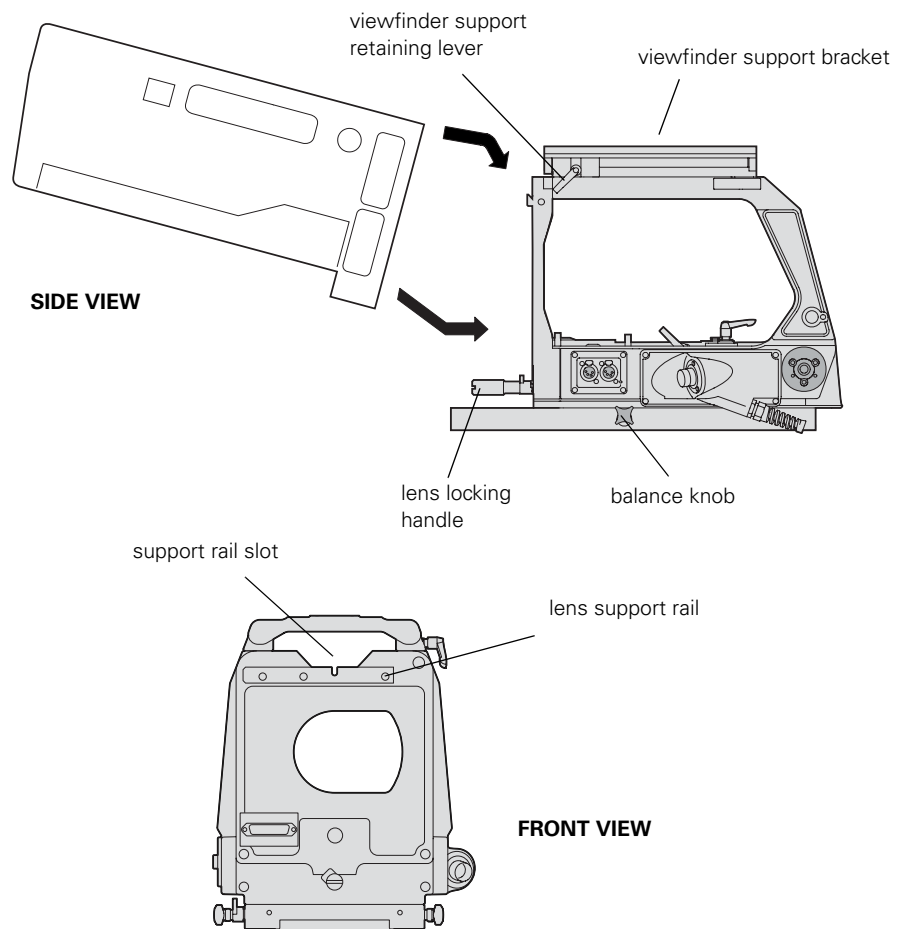

To mount the lens onto the SuperXpander/Xpander, proceed as follows:

1. Slide the viewfinder support back towards the rear of the SuperXpander/Xpander.
2. When the camera is mounted (in transport position) remove the lens cap before proceeding.
3. Hook the lens onto the support rail ensuring that the upper lens pin fits into the slot in the support rail.
4. Swing the lens downwards so that the lower lens pin fits into the hole in the front of the SuperXpander/Xpander.
5. Turn the lens locking handle clockwise to secure the lens in place.
6. If a zoom control is used, attach the zoom control cable to the lens.

3.4 Mounting a camera

To mount the camera into the SuperXpander/Xpander follow these instructions:

1. Make sure that the SuperXpander/Xpander is mounted firmly on the tripod.
2. Make sure that the **Quick Mount plate** inside the SuperXpander/Xpander is in the back position and that lever **B** is completely pulled out.
3. Slide the viewfinder support towards the front of the SuperXpander/Xpander.

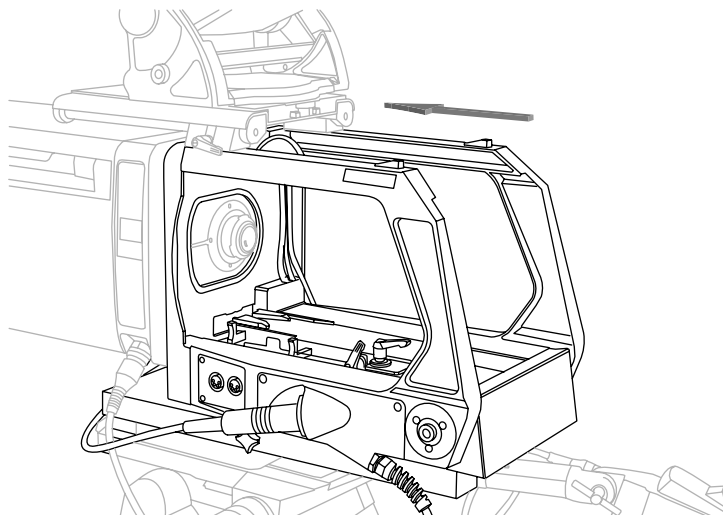

4. Hold the camera at a slight angle and place the front onto the **Quick Mount plate** behind the rear stud.
5. Level the camera and slide it forward slightly to rest on the **Quick Mount plate**.

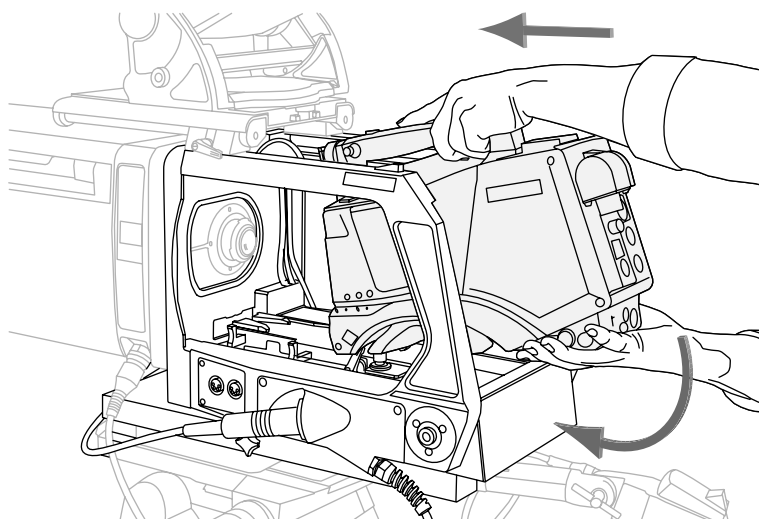

6. Connect the lens cable from the SuperXpander/Xpander to the lens connector at the side of the camera.
7. Connect the viewfinder cable from the SuperXpander/Xpander to the viewfinder connector at the side of the camera.

8. Push the camera all the way forward along the wedge-shaped groove until the rear stud engages the rear of the camera. When the camera is correctly locked into position lever **A** springs out.

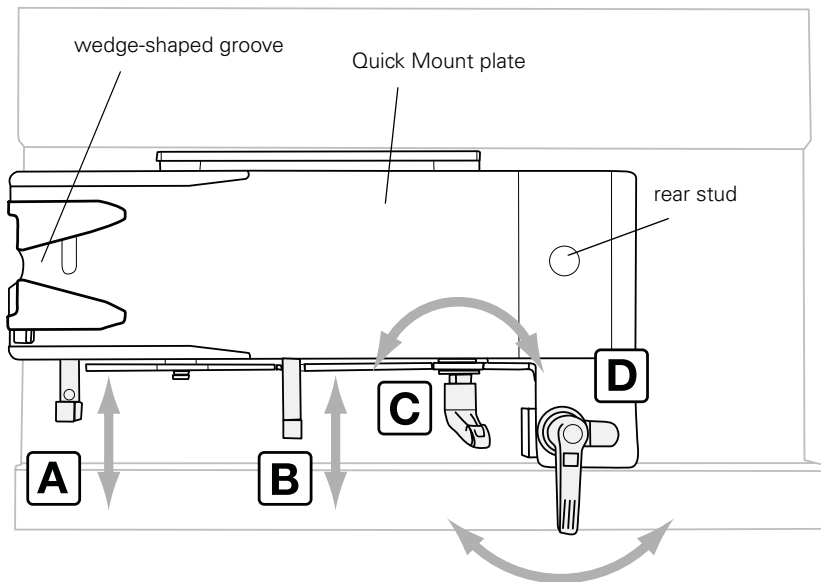

9. Adjust the position of the camera with levers **C** and **D** so that the bayonet ring engages the lens.

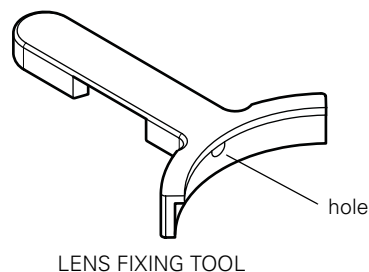

10. Use the supplied lens fixing tool to turn the bayonet ring lever on the front of the camera downwards so that the camera is connected to the lens. The adjustment pin on the bayonet ring fits into the hole of the fixing tool.
11. Tighten the levers **C** and **D** to secure the camera.
12. Plug the flying Triax lead from the left side panel of the SuperXpander/Xpander into the rear of the camera.
13. Connect the Triax cable from the Triaxbase station to the connector on the left side of the SuperXpander/Xpander.

3.5 Transport position

The SuperXpander/Xpander can be transported in a safe way without the need to remove the camera and the viewfinder. To bring the unit into transport position proceed as follows:

1. Remove the mains power lead (if used) and the Triax or fiber cable from the SuperXpander/Xpander. Remove any plugs from the utility power and a script board if used.
2. If a zoom control is used, remove the zoom control cable from the lens and the zoom control handle.
3. Turn the bayonet ring lever on the front of the camera upwards to disconnect the lens from the camera.
4. Remove the lens as described in the section [“Mounting a lens” on page 23](#).
5. Release lever **D** to loosen the camera and press lever **A** to release it.
6. Gently pull back the camera until lever **B** is pushed out and the camera is locked.
7. Tighten lever **D** to secure the camera. Leave lever **C** in the current position.
8. Slide the viewfinder support all the way back and rotate the viewfinder 180 degrees to the left. Lift and tilt the viewfinder until it is in the lowest horizontal position and fix this position with the proper handles.
9. The SuperXpander/Xpander is now ready for safe transportation.

3.6 Camera balance

When the lens and camera are mounted on the SuperXpander/Xpander it may be necessary to balance the SuperXpander/Xpander on the tripod as follows:

1. Loosen the balance knob on the side of the footbed by turning it counterclockwise.
2. Move the footbed back and forth along the tripod until the best balance is achieved.
3. Ensure that the ribs mesh correctly. The red ring on the balance knob should be barely visible.

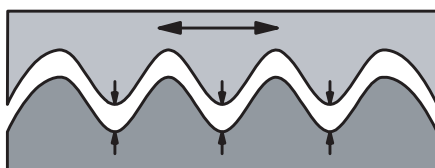

4. Tighten the balance knob on the side of the footbed by turning it clockwise.

3.7 Cable clamp

When the lens and camera are mounted on the SuperXpander/Xpander it is necessary to clamp the camera Triax or fiber cable. Proceed as follows:

1. Loosen the cable clamp on the right side of the footbed by turning it counterclockwise.
2. Put the cable into the clamp.
3. Tighten the cable clamp by turning it clockwise.
4. When connected to the camera, run the flying lead through the bottom clamp at the rear of the SuperXpander/Xpander to keep it from blocking the control panel. When not connected to the camera, run it through both clamps.

3.8 Mounting a scriptboard

An optional scriptboard can be mounted on the right or left side of the SuperXpander/Xpander. To mount the scriptboard onto the SuperXpander/Xpander insert the pin into the scriptboard hole of the SuperXpander/Xpander. Tighten the screw and adjust the scriptboard.

Chapter 4

Control panel

4.1 Buttons

The LDK 4488 SuperXpander is equipped with a control panel at the rear of the unit . This panel includes an LCD screen and buttons for controlling the camera and the viewfinder. The buttons on the control panel have coloured backlighting that indicates the state of the button.

Button state	Description
Blue	Function is available but not selected.
Yellow	Function is selected and active.
Yellow (blinking)	Function is selected but has unusual behaviour.
Off	Function is unavailable.

4.2 LCD display panel controls

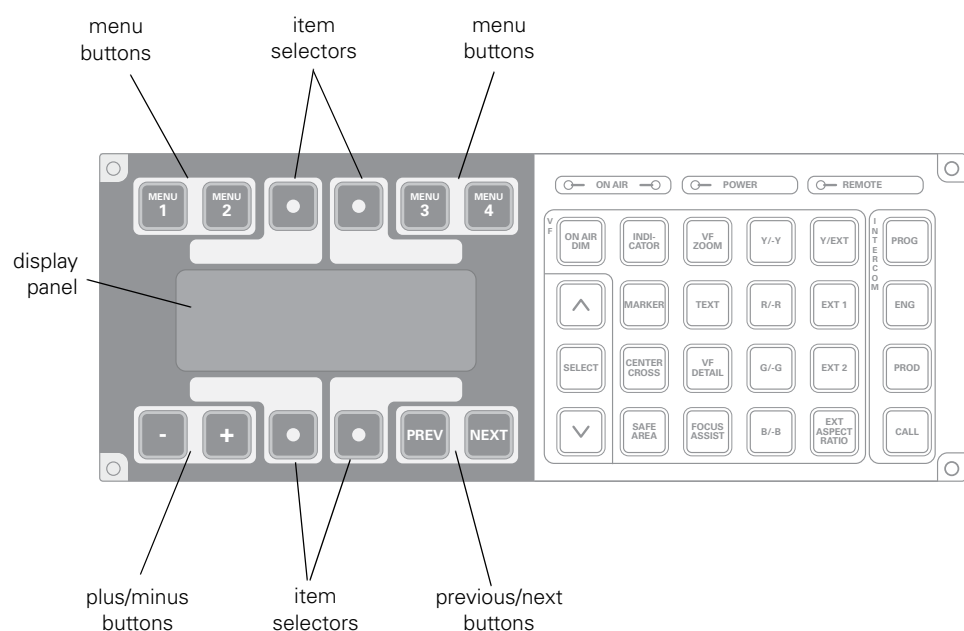

4.2.1 LCD display

The LCD display shows menus, items and values. When no menu is selected the display shows a status screen that includes the transmission mode and the current power status.

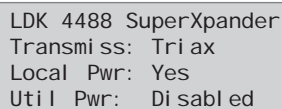

```
LDK 4488 SuperXpander
Transmiss: Tri ax
Local Pwr: Yes
Util Pwr: Disabled
```

4.2.2 Menu buttons

The system functions are divided into menus 1 to 4:

- Menu 1 contains functions for controlling the SuperXpander.
- Menu 2 contains camera functions.
- Menu 3 contains viewfinder related functions.
- Menu 4 contains lens related functions.

When a menu button is selected, it becomes yellow. Pressing a selected menu button again returns the status screen.

4.2.3 Prev/Next buttons

The **Prev** and **Next** buttons scroll through the pages in multipage menus.

4.2.4 Item selectors

Each one of the four item selector buttons is associated with an item displayed on the screen either at the top-left, top-right, bottom-left or bottom-right of the screen. When you tap one of these buttons the associated item becomes active. It can now be changed using the plus/minus buttons or toggled when the item has only two possible options.

4.2.5 Plus/minus buttons

These buttons are used to increase or decrease the value of an analog function or to select values for a function.

4.2.6 Menu function lists

The following tables provide an overview of functions included in the SuperXpander control panel. Note that the availability of some functions depends on your camera configuration.

Menu 1

switch	function	values	description
< page 1 >			
top-left	LCD Backl	0..99 (50)	Sets LCD backlight level.
top-right	LCD Contr	0..99 (70)	Sets LCD contrast level.
bottom-left	LED Blue	0..99 (50)	Sets light level for blue indicator LEDs.
bottom-right	LED Yellow	0..99 (50)	Sets Light level for yellow indicator LEDs.
< page 2 >			
top-left	Indicator	Zm,Fc,Ir, Zm/Fc,Zm/Ir	Assignment of the indicator button to either zoom, focus and/or iris indicator in the VF.
top-right	ENG switch	momentary, alternating	Choice between momentary or alternating behaviour of the ENG switch.
bottom-left			
bottom-right	Zoom SW	momentary, alternating	Choice between momentary or alternating behaviour of the Zoom switch.
< page 3 >			
top-left	Utility Power	0..12V (0)	Sets the variable utility power voltage in steps of 0.25V. <i>Note: this option is only available when the utility power is installed.</i>
top-right	Utility Power Status	Disabled, Overload, Ok, Unavailable	Indicates the status of the utility power. <i>Note: this option is only available when the utility power is installed.</i>
bottom-left	Local Power	Yes, No	Indicates if the SuperXpander is locally (AC) powered.
bottom-right	Transmission	Triax, Fiber, Unknown	Indicates which type of transmission unit is installed.
< page 4 >			
top-left	SXP software version	v00.00	Indicates the version of the software of the SuperXpander.
top-right	SXP boot software version	v00.00	Indicates the version of the boot software of the SuperXpander.
bottom-left	-		
bottom-right	Temperature	xxC/xxF	Temperature of SuperXpander (displayed in degrees C and F)

Menu 2

switch	function	values	description
<page 1 >			
top-left	ND Filter	1-4	Control of the ND Filter in the camera. If the filter is not motorized this is an indication.
top-right	FX Filter	A-D	Control of the FX filter in the camera, if available.
bottom-left	AutoWhite	Off,Window, On,Fail	Control of the Auto White balace process.
bottom-right	Bars	On,Off	Control of the Color Bar test signal.

Menu 3

switch	function	values	description
< page 1 >			
top-left	Lamp	Off, On	Switches the 7-inch viewfinder On Air lamp and Lens On-Air lamps.
top-right	-		
bottom-left	-		
bottom-right	-		

Menu 4

switch	function	values	description
< page 1 >			
top-left	-		
top-right	Iris Ind.	F1.4 .. Fclose	Indication of the current Iris position in F-stops.
bottom-left	Focus Ind.	0..99	Indication of the current focus position in a 0..99 range.
bottom-right	Zoom Ind.	0..99	Indication of the current zoom position in a 0..99 range.
< page 2>			
top-left	-		
top-right	-		
bottom-left	Range Extender	Off, On	Indication of the lens range extender.
bottom-right	-		
< page 3 >			
top-left	Lens I/F	Analog, Digital	Indication of the lens interface currently in use.
top-right	link state	OK, Not OK	indication of the status of the transmission module.
bottom-left	-		
bottom-right	-		

4.3 Panel controls

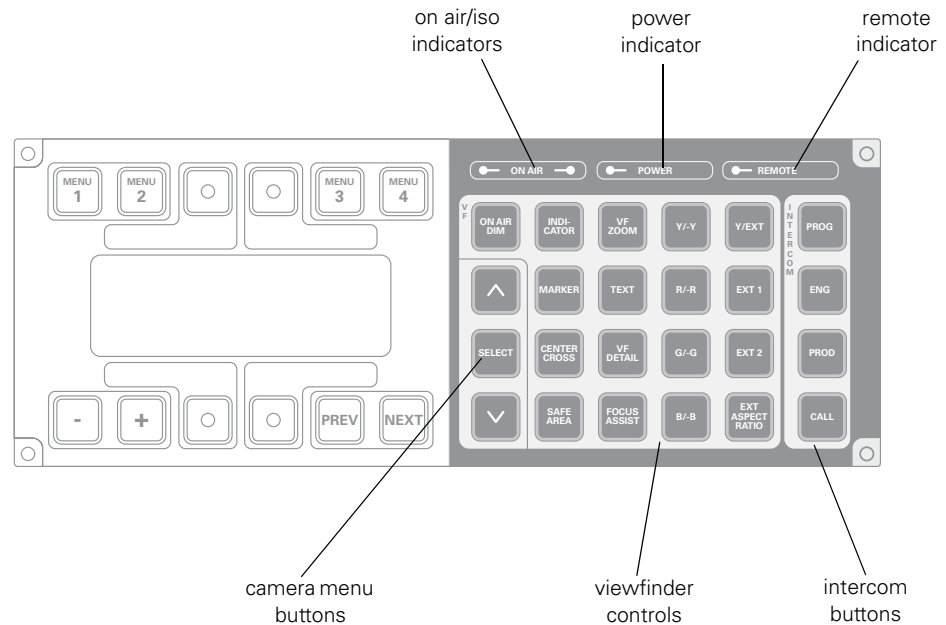

4.3.1 Camera menu buttons

These **Up**, **Down** and **Select** buttons are used to navigate and select functions in the camera menu system. The camera menu is displayed on the viewfinder. These buttons operate in the same way as the **Rotary** and **Select** buttons on the front of the camera.

4.3.2 Indicators

The three indicators at the top of the panel show the following:

Indicator	Description
On Air	Lights RED when the camera is on air.
	Lights YELLOW when the ISO signal is activated.
Power	Lights when the SuperXpander is receiving power.
Remote	Lights when the camera is in the remote control mode.

4.3.3 Viewfinder control buttons

This group of buttons controls what is displayed in the viewfinder

Switch	Function
ON AIR DIM	Switches the brightness of the On Air lamp on the viewfinder up and down in steps.
INDICATOR	Turns all indicators on the viewfinder screen On or Off
MARKER	Turns the marker indicator in the viewfinder on and off.
CENTER CROSS	Turns the centre cross indicator in the viewfinder on and off.
SAFE AREA	Turns the safe area indicator in the viewfinder on and off.
VF ZOOM	Turns the viewfinder zoom on and off.
TEXT	Turns the text display in the viewfinder on and off.
VF DETAIL	Turns the viewfinder detail on and off.
FOCUS ADSSIST	Turns the focus assist system in the viewfinder on and off.
Y/-Y R/-R G/-G B/-B	Switches the R, G, B or Y signal or their inverse from the camera for display in the viewfinder.
Y/EXT	Y/EXT ON switches a mix of Y + EXT 1 or Y + EXT 2 signal for display in the viewfinder. Y/EXT OFF switches only EXT 1 or EXT 2 signal for display in the viewfinder.
EXT 1 EXT 2	Switches the External video 1 and External video 2 signal for display in the viewfinder. Ext 1 and Ext 2 are also selectable with the pan-bar switches at the back of the handle. If no switch is selected the previous signal is displayed. NOTE: the viewfinder and external selection switches on the camera adapter are disabled.
EXT ASPECT RATIO	Selects the aspect ratio of the external signal.

4.3.4 Intercom control buttons

The intercom control buttons route the various intercom signals.

4.3.5 Call switch

Pressing this button sends a signal to the control panels calling for attention. An incoming call activates the LED in the switch.

Chapter 5

Power

5.1 Switching on power

Use the **On/Off switch** on the right side panel to switch the SuperXpander/Xpander and camera on and off. The On/Off indicator lights when the system is switched on.

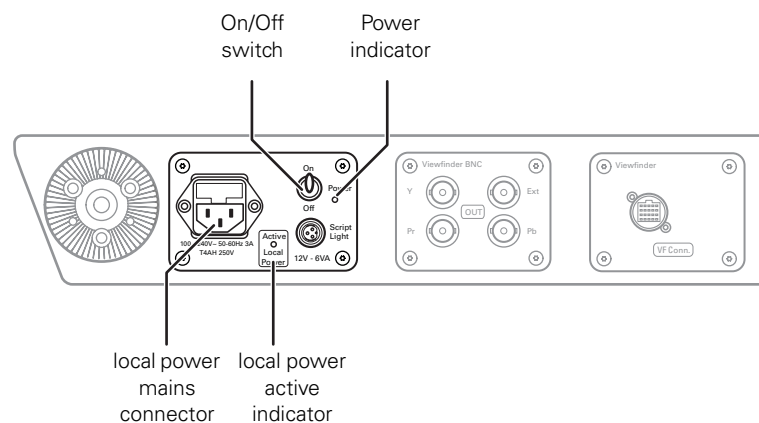

5.2 Remote power mode

In remote power mode, the SuperXpander/Xpander, camera and viewfinder are powered by the base station via the Triax or hybrid fiber cable. The SuperXpander/Xpander is not connected to the mains.

Triax cable lengths

When the Triax transmission module is installed and the SuperXpander/Xpander operates in remote power mode the maximum length of the Triax cable highly depends on the amount of power drawn by the utility power outlet(s). All power needs to be transported via the Triax cable.

The following table gives an approximation of the maximum Triax cable length versus utility power consumption (the nominal SuperXpander/Xpander system power consumption is already taken into account for these values).

Utility power:	Triax cable (8 mm)	Triax cable (11 mm)	Triax cable (14 mm)
0 VA	430 m (1,400 ft)	860 m (2,820 ft)	1,720 m (5,640 ft)
25 VA	360 m (1,180 ft)	720 m (2,360 ft)	1,450 m (4,760 ft)
50 VA	300 m (980 ft)	610 m (2,000 ft)	1,220 m (4000 ft)
75 VA	260 m (850 ft)	520 m (1,700 ft)	1,030 m (3,380 ft)
100 VA	220 m (720 ft)	440 m (1,440 ft)	870 m (2,850 ft)
120 VA	190 m (620 ft)	380 m (1,250 ft)	760 m (2,500 ft)

Fiber cable lengths

The maximum length of cable that can be used without significant degradation of the video signal is 4,000 m (13,000 ft).

- Overall fiber cable length highly depends on the optical budget, determined mainly by the number of optical transitions (interconnections).
- The hybrid fiber cable length is also limited by the total amount of power drawn by the SuperXpander/Xpander system, including camera, viewfinder and utility power.

5.3 Local power mode

When power is provided at the mains connector, the SuperXpander/Xpander automatically switches to local power mode. The local power active indicator lights to indicate that power is being supplied via the mains connector.

Local power mode is recommended for high power situations and/or long Triax cable runs. As an addition to the Triax infrastructure an LDK 4800 Triax repeater unit can be used to extend Triax cable lengths.



Note

When the SuperXpander/Xpander is used in local power mode the utility power is not available.



Note

Local power mode is not fully supported when using the SuperXpander/Xpander in a Fiber configuration. Power to the camera is still supplied by the base station while the SuperXpander/Xpander itself and the viewfinder are powered locally.

5.4 Utility power



Note

When the SuperXpander/Xpander is used in local power mode the utility power is not available.

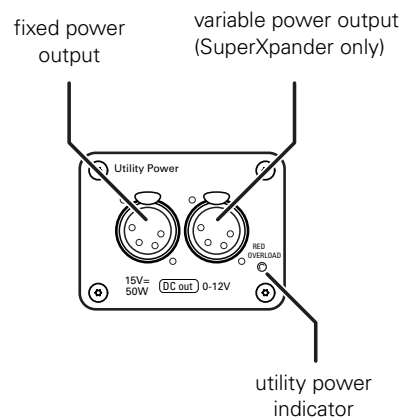

SuperXpander

When the utility power unit is installed two power outputs are available. The socket on the left provides a fixed voltage of 15 VDC. The socket on the right provides a variable voltage between 0 VDC and 12 VDC that can be set in the menu (menu 1 > page 3) of the control panel.



Note

The maximum power consumption of the variable output should not exceed 50 W and the power consumption of both outputs combined should not exceed 120 W. When the variable output is not used, the fixed output can deliver max. 120 W.

Xpander

When the utility power unit is installed only one power output is available. The socket on the left provides a fixed voltage of 15 VDC. The socket on the right is not used. Power consumption is max. 120 W.

Power indication

The utility power indicator provides information about the power output(s):

Indicator	Description
YELLOW	Normal operation. Power is available.
RED	Power overload on the variable power output (applies to the SuperXpander only)
Off (in remote mode)	In remote mode this indicates that there is a power overload on the fixed power output.
Off (in local mode)	In local mode this indicates that the utility power unit is switched off.

Temperature warning system

When the temperature inside the SuperXpander/Xpander becomes too high, the variable power output is switched off and a warning message is shown on the LCD display. When the temperature increases even more, the fixed power output is switched off as well and another warning message is shown.

The table below shows detailed information about the temperature warning system:

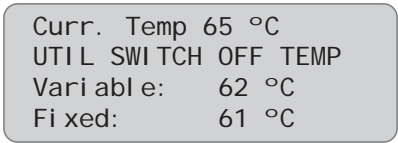
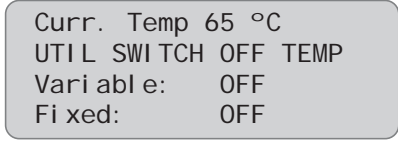
Fixed output	Variable output (SuperXpander only)	Action
below 60°C	below 59 °C	normal operation
from 60 °C up to 65 °C	from 59 °C up to 64 °C	The following warning message is shown on the LCD display of the control panel (SuperXpander only). 
65 °C and higher	64 °C and higher	The power output is switched off and the following warning message is shown on the LCD display of the control panel (SuperXpander only). 
63 °C or lower	62 °C or lower	The power output is switched back on again. No warning will be shown as long as the temperature decreases.

Chapter 6

Connectors

6.1 Left side view

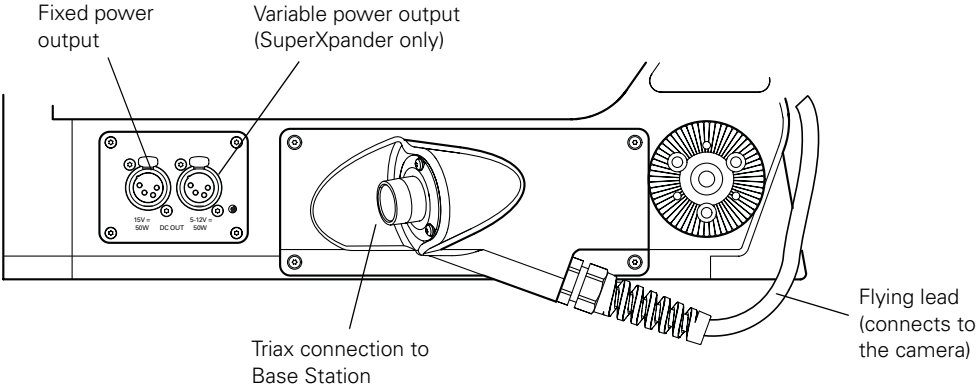
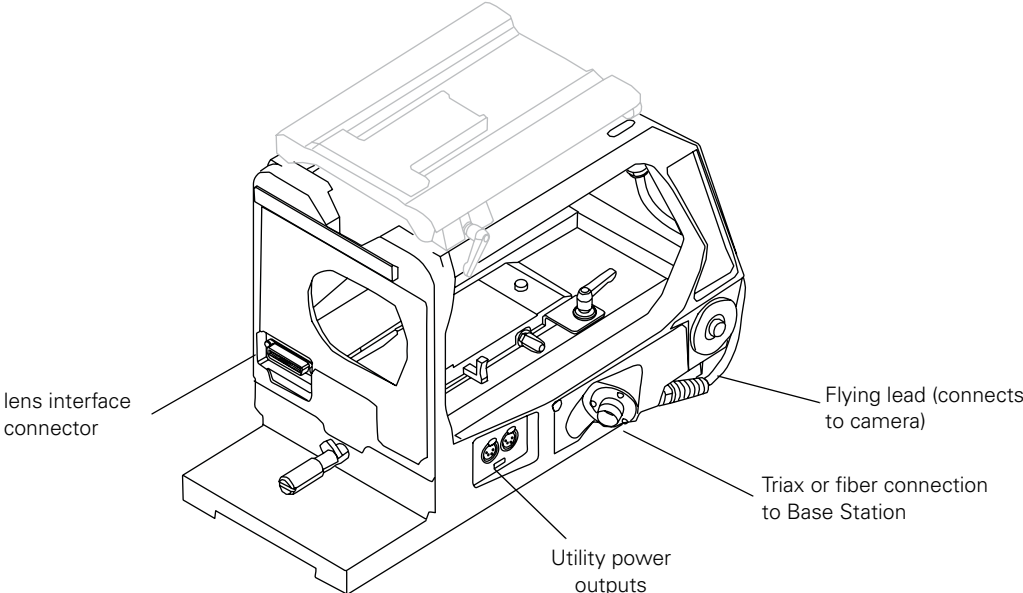

6.1.1 Fixed utility power output (option)

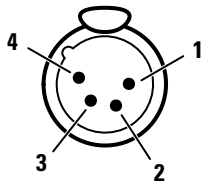

XLR 4-pin male

Pin	Description
1	GND
2	no connection
3	no connection
4	+15 VDC

6.1.2 Variable utility power output (option, SuperXpander only)

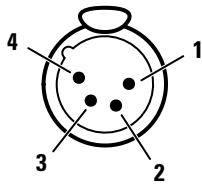

XLR 4-pin male

Pin	Description
1	GND
2	no connection
3	no connection
4	0 to 12 VDC*)

*) variable, can be set in the operation panel.

6.1.3 Lens interface connector

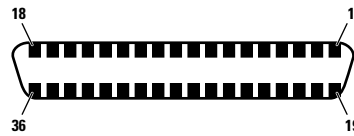

36-pin Centronics connector

Pin	Description	Pin	Description	Pin	Description
1	no connection	13	Zoom control	24	Lens ID0
2	no connection	14	Ext switch 1	25	Lens ID1
3	no connection	15	Ext switch 2	26	Lens ID2
4	Lens power (+15 VDC)	16	Zoom/focus local/remote or Exit pupil pos	27	Lens ID3
5	Lens power return	17	Iris control	28	no connection
6	GND	18	Iris auto/remote or TxD	29	no connection
7	Housing	19	Zoom control	30	Focus follow
8	Re A or RXD	20	Focus control	31	Image stabilizer
9	Re B	21	Tally control	32	no connection
10	Re C or Aspect ratio follow	22	Zoom/focus local/remote or Exit pupil pos	33	ENG switch
11	Heater	23	no connection	34	PROD switch
12	Iris follow			35	no connection
				36	no connection

6.2 Right side view

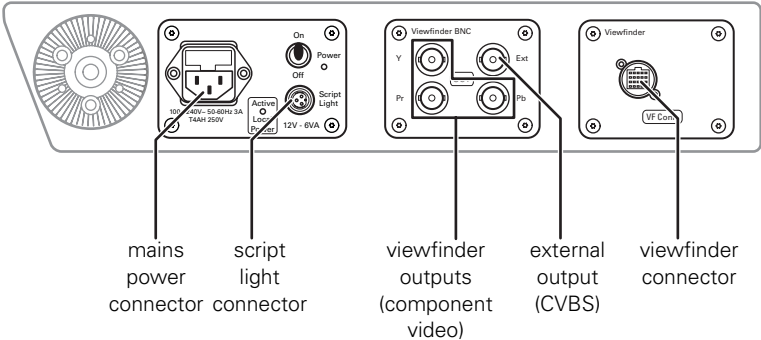
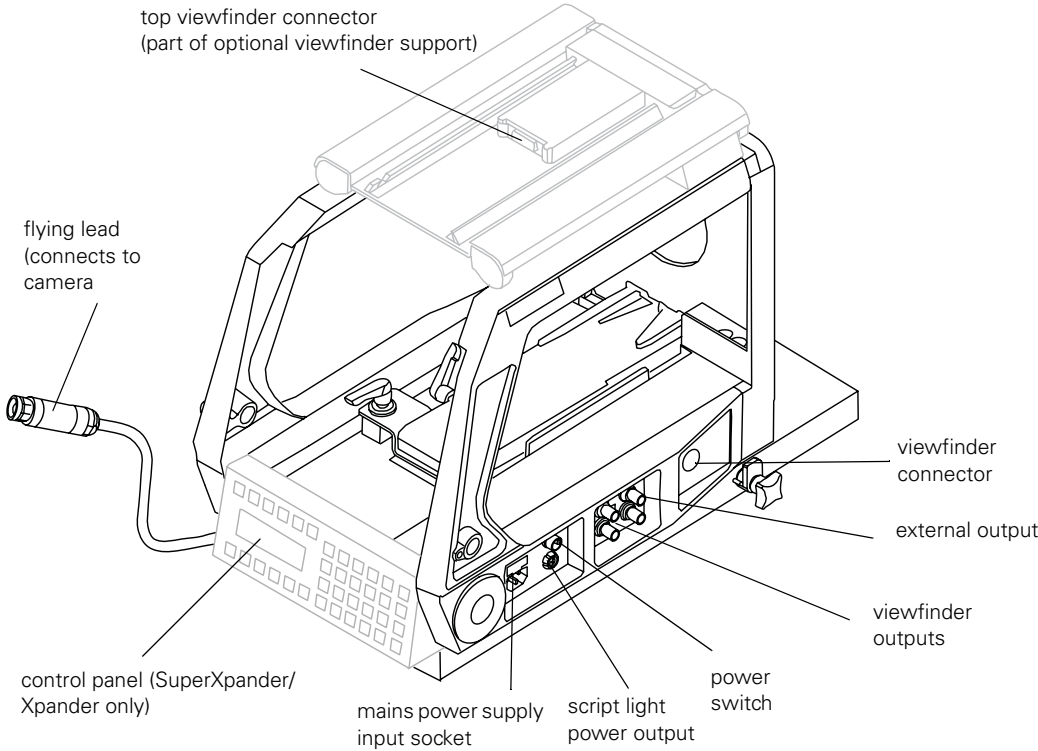

6.2.1 Mains power supply input socket

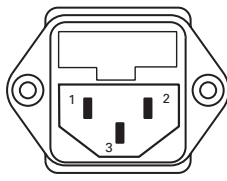

3-pin Euro connector

Pin	Description
1	Neutral
2	Phase
3	Earth

Mains input voltage: 100 to 240 VAC (auto ranging)

Mains frequency: 50 to 60 Hz

Fuses (2): T4.0 A H250V

6.2.2 Script light connector

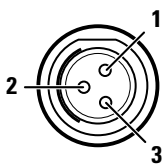

Fischer 3-pin female connector

Pin	Description
1	+12 VDC (max. 6 W)
2	GND
3	Shield

NOTE: the script light connector is different than the one on the camera adaptor!

Manufacturer/type: Fischer DBP 103 A052-28

6.2.3 Viewfinder component outputs (3x)



BNC connector

These 3 BNC sockets provide video output (component video) of the viewfinder signal.

Y (1.0 Vpp with sync), Pr (0.7 Vpp), Pb (0.7 Vpp);

6.2.4 External CVBS output



BNC connector

This BNC socket provides CVBS analog video output (1.0 Vpp)

The source for this output (EXT1 or EXT2) can be selected on the control panel of the SuperXpander or in the camera (Xpander)

6.2.5 Camera viewfinder connector

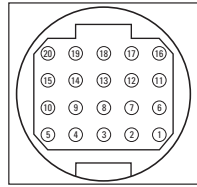

20-pin female VF-connector

Pin	Description	Pin	Description
1	-55 VDC	11	GND
2	not connected	12	VF video
3	GND	13	Pb VF return
4	INTN-D	14	Pr VF return
5	VF Ext video	15	GND
6	not connected	16	+ Batt
7	VF video return	17	+ Batt
8	SDA-D	18	Pb VF
9	SCL-D	19	+Pr VF
10	VF Ext video return	20	Shield

6.2.6 Top viewfinder connector (part of optional viewfinder support)

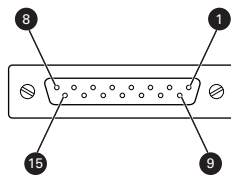

15-pin female D-sub connector

Pin	Description	Pin	Description
1	VF video	9	VF video return
2	VF Ext Video	10	VF Ext video return
3	VF Pb	11	+15 VDC
4	GND	12	GND
5	Shield	13	Shield
6	+15 VDC	14	VF Pr
7	SCL- D	15	SDA-D
8	INTN-D		

Chapter 7

Specifications

7.1 Specifications for LDK 4488, LDK 4489

Item	Value
Power	
Power requirements	100 to 240 VAC; 50 to 60 Hz 3 A; fuses (2x): T4.0 AH 250 V
Power consumption	250 VA max. fully equipped
Power connection	IEC type 3-pin male
Environment	
Operating temperatures	0°C to +45 °C (32 to +113 °F)
Storage temperatures	-20 °C to +60 °C (-4 to +140 °F)
Weight (approx.)	14.4 kg (31.7 lbs) without viewfinder support
Dimensions (L x W x H)	526 x 286 x 385 mm (20.7 x 11.3 x 15.2 in) without viewfinder and lens
Power outputs	
Utility power output 1 (fixed)	15 VDC; XLR-4 female connector, $P_{max} = 120\text{ W}$ *)
Utility power output 2 (variable) (SuperXpander only)	0 to 12 VDC; XLR-4 female connector, $P_{max} = 50\text{ W}$
*) The maximum power consumption of the two utility outputs combined is 120 W	
Script light output	12 VDC; $P_{max} = 6\text{ VA}$; Fischer 3-pin female connector type DBP 103 A052-28
Connections	
Lens interface	36-pin Centronics female connector
External CVBS output	1.0 Vpp ~ 75 Ohm; BNC socket
External Components outputs	Y (1.0 Vpp with sync.), Pr (0.7 Vpp), Pb (0.7 Vpp); 3x BNC sockets
VF connector (camera)	20-pin female VF connector
VF connector (top)	15-pin Sub-D connector, female

7.2 Dimensions

Figure 7-1. Dimensions of the LDK 4488 SuperXpander with Triax transmission unit

