

SONY®

NTSC/PAL

3CCD Digital Camcorder

DVCAM®

Innovative camcorders for field and studio applications

DSR-570WS/570WSP

DSR-370/370P



F o r

P r o f e s s i o n a l

R e s u l t s

A compact and powerful solution for both field and studio applications

Ever since their introduction, Sony DSR-500WS and DSR-300A Digital Camcorders have shown the many distinct advantages of using the DVCAM format in the field. Today, they are in service around the world in a variety of applications, from video journalism and newsgathering to event videography, field and studio production and much more.

Building on this success, Sony now announces the DSR-570WS*¹ and DSR-370*² – DVCAM camcorders that take the advantages of their predecessors further still.

As well as combining the excellent performance of the DVCAM format with a variety of advanced camera features, these camcorders also allow studio operation via CCU control. Both camcorders come equipped with the Sony 26-pin connector, which enables connection to either a Sony CCU-M5A*³ for use in the studio, or to a portable VTR for high-quality EFP applications in the field.

Special attention to ergonomic design has resulted in extremely lightweight and compact units, providing maximum operational comfort when used on the shoulder or mounted on a tripod.

The DSR-570WS and DSR-370 herald a new level of quality, versatility and convenience for virtually any application, ranging from ENG to EFP and to multi-camera studio operations.

*¹ “DSR-570WS” refers to the DSR-570WS (NTSC model) and DSR-570WSP (PAL model). *² “DSR-370” refers to the DSR-370 (NTSC model) and DSR-370P (PAL model).

*³ “CCU-M5A” refers to the CCU-M5A (NTSC model) and CCU-M5AP (PAL model).

Lens, Synthesized Tuner and Battery are optional.



DSR-570WS

The DSR-570WS is the top-of-the-line DVCAM camcorder that shoots in both widescreen 16:9 and standard 4:3 aspect ratios. Equipped with three 2/3-inch type Power HAD WS™ CCDs, it achieves a high resolution of 850 TV lines in 4:3 mode or 800 TV lines in 16:9 mode. It delivers the superb picture quality required to support virtually any creative shooting environment.

DSR-370

The DSR-370 is a high-quality DVCAM camcorder designed specifically for 4:3 aspect ratio acquisition. With its three high-performance 1/2-inch type Power HAD™ CCDs, it boasts a high resolution of 800 TV lines and packs the same functionality as the DSR-570WS.

for the Studio



for Field Production and News



for Event Production



DSR-570WS & DSR-370 Innovative features

Two models designed to meet the stringent requirements of a variety of users

DSR-570WS/370



	DSR-570WS	DSR-370
Horizontal resolution	850 TV lines (4:3 mode)/800 TV lines (16:9 mode)	800 TV lines
CCD	Three 2/3-inch type CCDs (Power HAD WS CCD)	Three 1/2-inch type CCDs (Power HAD CCD)
Aspect ratio	16:9/4:3 switchable	4:3
Lens mount	2/3-inch type bayonet mount	1/2-inch type bayonet mount
Hyper Gain	36 dB or 42 dB	36 dB
Mass (Camcorder body only)	3.6 kg (7 lb 15 oz)	3.3 kg (7 lb 4 oz)

DSR-570WS features

2/3-inch type Power HAD WS CCD

The DSR-570WS is equipped with three 2/3-inch type Power HAD WS CCDs, each with a high density of 520,000 pixels (NTSC)/570,000 pixels (PAL). These CCDs were originally designed for the 16:9 aspect ratio, therefore high-quality images can be obtained in the 16:9 mode with virtually no image loss. A high sensitivity of F11 (at 2000 lx, 3200 K), remarkable signal-to-noise ratio of 63 dB* (NTSC)/61 dB*(PAL) and a low vertical smear level of -120 dB are also important specifications of this camcorder. * Typical

Switchable aspect ratio

Wide-aspect CCDs and digital signal processing allow the DSR-570WS to operate in both widescreen (16:9) and standard (4:3) aspect ratio modes. When

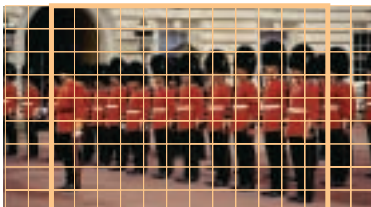

shooting in 16:9 mode, it is also possible to display both 16:9 and 4:3 safety zones in the supplied DXF-801 viewfinder.

16:9 ID pulse

When shooting 16:9 images, the DSR-570WS automatically adds a wide-aspect ID pulse to the video output signal, indicating the aspect ratio of the picture. The 16:9 information is also recorded onto the Video Auxiliary (VAUX) area of a DVCAM tape, together with the video signals.

Encoding circuit

The DSR-570WS performs digital-to-analog encoding in a wide signal-bandwidth range. This contributes to its high horizontal resolutions of 850 TV lines (in 4:3 mode) and 800 TV lines (in 16:9 mode).

DSR-370 features

1/2-inch type Power HAD CCD

The DSR-370 is equipped with three 1/2-inch type Power HAD CCDs, each with a high density of 380,000 pixels (NTSC)/430,000 pixels (PAL).

These allow for a high sensitivity of F11 (at 2000 lx, 3200 K) and a remarkable signal-to-noise ratio of 62 dB* (NTSC)/60 dB* (PAL). * Typical

DSR-570WS & DSR-370 Common features

Hyper Gain

At the flick of a switch, the Hyper Gain function enables shooting in the dark by drastically boosting the electronic gain. Using the Viewfinder (VF) Menu system, the Hyper Gain level can be set to a maximum of 42 dB for the DSR-570WS, or 36 dB for the DSR-370. This allows shooting in as low as 0.25 lx and 0.5 lx respectively.

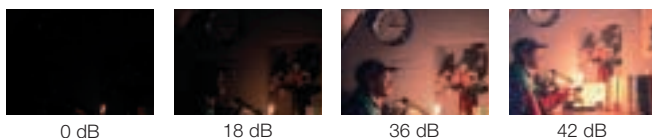

Camera Setup Files

Moving the SETUP switch to the FILE position allows a total of eight Camera Setup Files to be viewed with the VF (Viewfinder) Menu system. Five factory-preset files – including Standard, High Saturation, Fluorescent, Film-Like and S-VHS/VHS Condition match the most common lighting conditions, and an additional three user files allow the customization of camera parameters to particular shooting situations. With the SetupNavi™ function, the user files and factory-preset files can also be stored on the VAUX portion of a DVCAM tape.

High-quality DVCAM recorder

DSR-570WS/370 Features

Delivering high-quality, efficient, DVCAM recording

DVCAM recording

The VTR sections of both the DSR-570WS and DSR-370 use the Sony DVCAM format, providing the video and audio quality, and the reliability necessary for professional use. For excellent picture quality, superb multi-generation capabilities and excellent production flexibility, these camcorders feature 8-bit component digital recording, with a 5:1 compression ratio and a sampling rate of 4:1:1.

The DSR-570WS and DSR-370 can use both mini (PDVM Series) and standard (PDV Series) cassettes. Using the standard PDV-184ME cassette, these camcorders provide a maximum recording time of 184 minutes. They can also play back the consumer DV format – another great advantage of DVCAM.

Digital output to external devices

The DSR-570W and DSR-370 are equipped with a 6-pin i.LINK®* interface (DV output only) for digital signal output. This enables recording to compatible DV and DVCAM VTRs using just one i.LINK cable, which carries digital video/audio and control signals simultaneously. Connect the DSR-570WS or DSR-370 to the Sony DSR-70A/70AP Field Editor or DSR-2000/2000P Studio VTR**, for instance, and simple cut editing can be performed without signal deterioration. Or connect to a Sony DSR-50/50P portable DVCAM recorder, and control its Rec On/Off function remotely with the Rec On/Off button of the DSR-570WS or DSR-370.



* i.LINK is a trademark of Sony used only to designate that a product contains an IEEE 1394 connector. All products with an i.LINK connector may not communicate with each other. Please confirm interoperability with third party manufacturers.

** For this application, an optional board should be installed in the DSR-70A/70AP or the DSR-2000/2000P.

ClipLink™ system

The ClipLink system is a comprehensive management system of shooting information, – “ClipLink data”. Supporting this system, the DSR-570WS or DSR-370 records ClipLink data while shooting. In combination with Sony DVCAM VTRs and EditStation® non-linear editing systems, this data is carried from acquisition to editing, enhancing the productivity and operating efficiency throughout the entire digital video production process.*

* Requires installation of the optional DSBK-301A board.

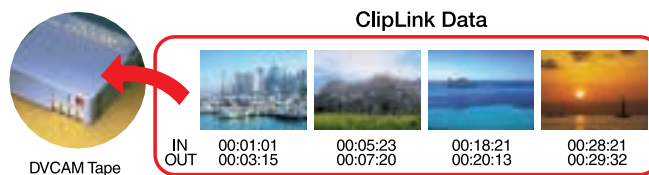

Freeze Mix function

The Freeze Mix function superimposes a previously recorded image on the viewfinder. This allows the operator to quickly and easily frame or reposition a subject when a shot must be taken from the same position or in the same framework as a previous take. Combined with the SetupLog™ function, this simplifies retakes.

Useful features for recording operation

The DSR-570WS and DSR-370 include a variety of features to simplify recording:

- **26-pin VTR interface** – feeds camera output signals to a portable recorder equipped with a 26-pin connector
- **Pool-Feed operation** with Optional DSBK-501 Analog Composite Input Board
- **Edit Search function** – for easy access to edit points
- **SetupLog** – automatically records camera-setting data for each shot onto the VAUX portion of a DVCAM tape

Digital-processing camera

DSR-570WS/370 Features

Capturing superior pictures with full Digital Signal Processing (DSP)

10-bit A/D DSP (Digital Signal Processing) LSI

The advanced Sony 10-bit DSP technology used in these camcorders delivers one of the best picture performances in the industry. Optimized digital-signal processing ensures excellent picture sharpness. And innovative camera features such as TruEye™ and DynaLatitude™ are also incorporated.

TruEye process

Sony's TruEye digital signal-processing technology virtually eliminates the hue distortion of conventional RGB analog or digital processing – particularly obvious in extreme lighting conditions. By processing video signal data at three levels – brightness, hue, and saturation – in a similar way to the human eye, the TruEye process assists in the reproduction of natural skin tones.



Conventional Camera



DSR-570WS (TruEye)

DynaLatitude function

DynaLatitude, a unique feature based on the TruEye process, minimizes video-level distortion. Based on video-signal histograms, the DynaLatitude function aligns the contrast of each pixel to eliminate imbalances such as the overexposure of background images.



Conventional Camera

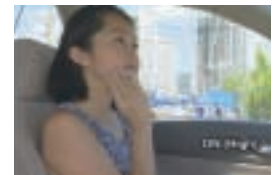

DSR-570WS (DynaLatitude)

Skin Tone Detail with auto-detection of active area

The Skin Tone Detail function gives the subject a pleasing facial complexion, while maintaining the sharpness of other areas. The designated active area of Skin Tone Detail can be set with the "Skin Set" button on the camera's side panel. The color range of the active Skin Tone Detail area and Skin Detail level can also be controlled.

Black Stretch/Compress

Contrast in the black area of an image can be easily adjusted using the Black Stretch/Compress control function. Black Stretch emphasizes the contrast in dark areas, while Black Compress enhances or deepens darkness.

Convenient and comfortable

DSR-570WS/370 Features

Combining comfort, operational convenience and simplicity

Compact and lightweight

The DSR-570WS and DSR-370 are remarkably small, thanks to high-density circuit boards and a smaller recording head drum. They weigh just 6.4 kg (14.1 lb 225.7 oz) and 6.2 kg (13.6 lb 218.6 oz) respectively, including the lens (VCL-919BY/719BX), viewfinder, tape, lithium-ion battery (optional BP-L40A) and microphone.

Low power consumption

The DSR-570WS and DSR-370 camera heads consume just 24 W and 20 W respectively. The BP-L90A lithium-ion battery provides the DSR-570WS with approximately 230 minutes of recording time, and the DSR-370 with approximately 290 minutes.

DynaFit™ shoulder pad

The DSR-570WS and DSR-370 are equipped with a DynaFit shoulder pad. It molds to any shoulder without slipping and maintains excellent balance, free from the painful pressure points common to harder shoulder pads.

Variable color temperature setting

In addition to four built-in filters, the DSR-570WS and DSR-370 enable small step adjustments to the color temperature to be made. When the filter is set to 3200 K, color temperature can be chosen from 19 steps in the range from 2200 K to 4300 K using the viewfinder menu. Similarly, 13 steps are available, ranging from 4600 K to 12000 K, when the filter is set to 5600 K. The set color can be recalled with the filter position. Using this function, artistic painting effects, such as adding a "sunset", can be easily performed without any special equipment.

Dual zebra

The DSR-570WS has two types of zebra patterns – ZEBRA 1 and ZEBRA 2. ZEBRA 1 can be set within a range of 70 IRE to 90 IRE, in one-IRE steps. ZEBRA 2 provides a zebra pattern in any area with a video level of more than 100%.

Remote control system

With the 10-pin REMOTE connector, designed in accordance with the RS-232C standard, the DSR-570WS and DSR-370 can be directly controlled from an optional Sony RCP-TX7* Remote Control Panel.

* The RCP-TX7 cannot be used in combination with the CCU-M5A.

Scene files from the RCP-TX7

With the optional RCP-TX7, up to 16 scene files can be created and stored. Almost all DSP-function and camera-setup parameters can be stored in a scene file, and the most suitable file for each shooting situation can be instantly recalled using the RCP-TX7's menu button.

Video Light Connector

Optional light equipment can be directly attached to the DSR-570WS and DSR-370 and powered from the video light connector. It can be turned on manually using the LIGHT switch on the front-right side of the camcorder, or synchronized with the REC start function.

Camera adaptor for wireless receiver

The optional CA-WR855 is an adaptor to hold a Sony WRR-855* Wireless Receiver. It can be directly attached to the DSR-570WS or DSR-370 via a V-shoe attachment, providing a direct connection interface for audio/power. A Lithium-ion battery can also be attached to the rear panel of the CA-WR855 via a V-shoe attachment, allowing easy battery replacement even when the WRR-855 is mounted.



Photo shows CA-WR855, WRR-855 and BP-L40A

The DSR-570WS and DSR-370 can also accommodate the WRR-861 Wireless Receiver using the A-8278-057-A**. * The 'WRR-855' includes both WRR-855A and WRR-855B. ** The A-8278-057-A is available as a service part.

DXF-801* Viewfinder

The DXF-801 is a 1.5-inch type black/white viewfinder supplied with the DSR-570WS and DSR-370, and includes the following features:

- **Automatic scan-size swapping between 16:9 and 4:3 (DSR-570WS only)**
- **VF Light (LED)** – lights up the iris ring area of the lens for operation in dark conditions (high/low/off)
- **DISPLAY switch** – turns off the character superimposition on the viewfinder
- **Tally lamp levels** (high/low/off)
- **Vertical and horizontal detail-level control** using a PEAKING potentiometer
- **Two red REC tally lamps**
- **TAKE tally lamp** for ClipLink operation, with a second tally lamp for CCU operations
- **Diecast aluminum body**
- **Wide range of diopter adjustments**

* The DXF-801 is available only as a service part.



DXF-801



Viewfinder Light

Easy operation

DSR-570WS/370 Features

Ensuring the best possible results with simple operation

Assist functions

In response to increasing demands for more automatic functions in a professional camera, the DSR-570WS and DSR-370 support camera operators with:

- **Total Level Control System (TLCS)** – offering proper exposure automatically
- **EZ Focus*** – to make manual focusing easier
- **EZ Mode** – to set the camera to a standard position instantly
- **Auto-Tracing White Balance (ATW)** – to adjust white balance in real time
- **Flexible safety zone marker**

The DSR-570WS and DSR-370 can display a 'safety zone marker' in a variety of selectable aspect ratios. This function comes in handy when shooting 16:9 material for 4:3 transmission or vice versa. The following shows the safety zone aspect ratios that are available when the camcorder is operated in 16:9 or 4:3 mode.

In 16:9 mode: OFF, 4:3, 13:9, 14:9, 15:9 (DSR-570WS only)

In 4:3 mode: OFF, 13:9, 14:9, 15:9, 16:9 (DSR-570WS and DSR-370)

* Not automatic focus

Jog-dial menu control

The DSR-570WS and DSR-370 incorporate a jog-dial that controls the viewfinder menu. Users can select the desired menu item and set the value with simple, one-fingered jog-dial operation. This jog-dial control means fewer buttons and switches, and therefore simplified operation.

To avoid misoperation

A switch guard prevents users inadvertently touching the EZ Mode, AUTO IRIS Mode and ATW buttons. The camcorders also include a slide-open cover for the VTR control buttons, of the type seen in many broadcast products. This prevents the buttons from being touched accidentally while carrying the camcorder. The cover is translucent so that the VTR operation status indicator can be seen through it.

Integration into the studio

DSR-570WS/370 Features

A cost-effective studio solution

Multicore CCU operation

In addition to enabling connection with portable VTRs, the 26-pin connector which is standard on the DSR-570WS and DSR-370 allows remote control from a Sony CCU-M5A Multicore Camera Control Unit. This affordable unit provides sophisticated remote controls for EFP or studio operations, and can be used for a wide range of applications.

■ **300m with CCZ-A cable (26-pin)** (150m for Return Video and Genlock)

■ **Two composite outputs – one Y/C and one component output** (selectable from Y/R-Y/B-Y and R/G/B)

■ **Control functions:**

IRIS (auto/manual), White Balance (auto/manual/preset), Black Balance (auto/manual/preset), Gain Select (low/mid/high), R/B Gain, R/B Pedestal, Master Pedestal, Sub-carrier Phase, Horizontal Phase, Output Mode (color bar/camera), Knee Point (auto/manual/preset), Detail Level, Tally/Intercom, Shutter Speed Selection, Clear Scan

■ **Video light power supplied from the CCU-M5A**

for applications such as on-air interviews.



CCU-M5A



26-pin connector

* The RM-M7G can be used in combination with the CCU-M5A.
The RCP-TX7 cannot be used in this configuration.

Intercom adaptor CA-370*

The DSR-570WS and DSR-370 offer intercom capability with the addition of an optional CA-370 Intercom adaptor, for communication between the camera operator and CCU-M5A operator. The CA-370 also allows connection of a Sony DR-100 headset and provides the associated audio volume controls. The convenient 'V-shoe mount' provides quick and stable connection between the camcorder and adaptor.

* The CA-370 cannot be used in combination with the CA-WR855.



Studio System with the CA-370 and DR-100

System configurations of studio application

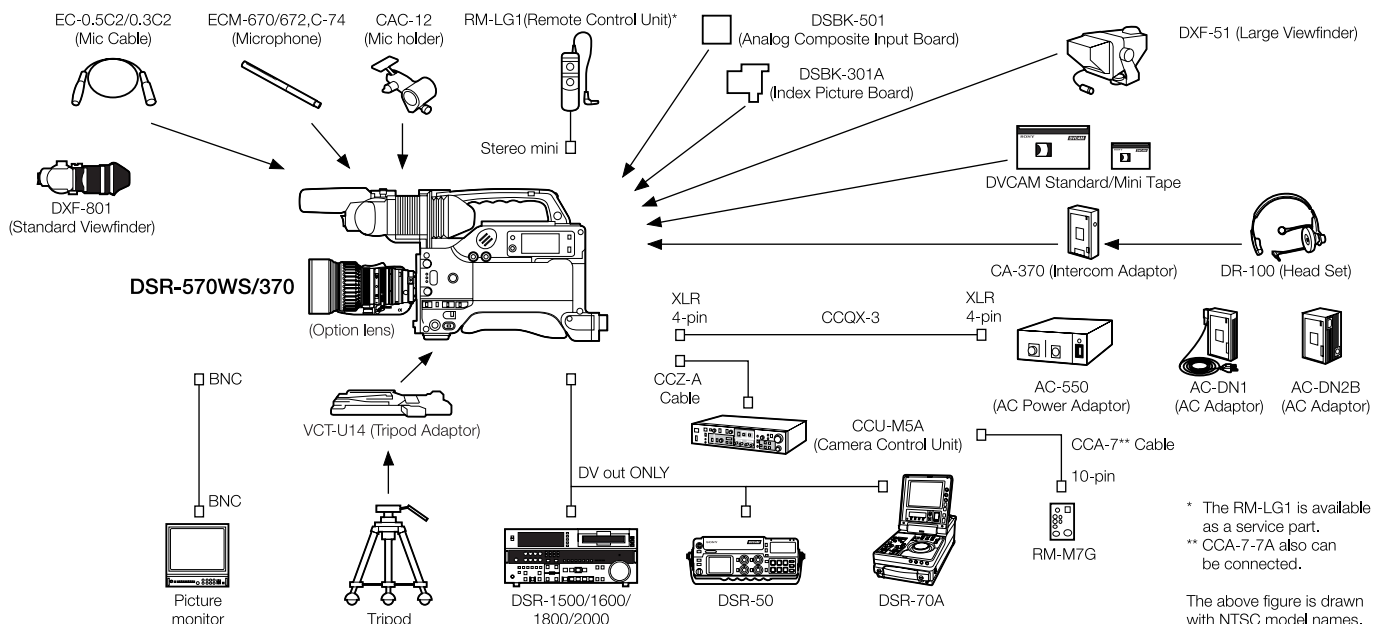

Optional accessories

 <p>CCU-M5A/M5AP Camera Control Unit</p>	 <p>RCP-TX7*1 Remote Control Panel (The RCP-TX7 cannot be used in combination with the CCU-M5A/M5AP)</p>	 <p>RM-M7G Handy Remote Control Unit (The RM-M7G does not include the CCA-7 cable)</p>	 <p>CA-370 Intercom Adaptor</p>	 <p>DR-100 Headset</p>
 <p>CA-WR855 Camera Adaptor for WRR-855A/855B</p>	 <p>WRR-855A/855B UHF Synthesized Diversity Tuner (Wireless microphone receiver)</p>	 <p>WRR-861A/861B*2 UHF Synthesized Diversity Tuner (Wireless microphone receiver)</p> <p>A-8278-057-A</p>	 <p>DSBK-301A Index Picture Board</p>	 <p>DSBK-501 Analog Composite Input Board</p>
 <p>ECM-670/672 Electret Condenser Microphone</p>	 <p>CAC-12 Microphone Holder</p>	 <p>VCT-U14 Tripod Adaptor</p>	 <p>DXF-51 5-inch type B/W Viewfinder</p>	 <p>DSR-70A/70AP Portable Editing Recorder</p>
 <p>DSR-2000/2000P Digital Videocassette Recorder</p>	 <p>BP-L40A*3/L60A/L90A Rechargeable Li-ion Battery Pack</p>	 <p>BP-M50/M100 Rechargeable Nickel Metal Hydride Battery Pack</p>	 <p>BC-M50 Battery Charger for BP-L40A/L60A/L90A/M50/M100</p>	 <p>BC-L50 Battery Charger for BP-L40A/L60A/L90A</p>
 <p>BC-L120 Battery Charger for BP-L40A/L60A/L90A/NP-1B/BP-90A</p>	 <p>AC-550 AC Adaptor</p>	 <p>AC-DN1 AC Adaptor (for operation under 38 W)</p>	 <p>AC-DN2A AC Adaptor (for operation under 150 W)</p>	 <p>LC-300SZ Carrying Case (soft type)</p>
 <p>LC-424 Carrying Case (hard type)</p>	 <p>LCR-1 Rain Cover</p>	 <p>VCL-716BX 1/2-inch type Format 16x Lens (for DSR-370/370P K2pack)</p>	 <p>A20x8.6BRM-SD 2/3-inch type Format 20x Lens from Fujinon. (for DSR-570WS/570WSP)</p>	 <p>S20x6.4BRM-38 1/2-inch type Format 20x Lens from Fujinon. (for DSR-370/370P)</p>
 <p>W80Y-50 Wide Conversion Lens Adaptor from Canon</p>	 <p>CCFD-3L i.LINK cable (6-pin with lock*4 - 4-pin) CCF-3L i.LINK cable (6-pin with lock*4 - 6-pin)</p>	<p>*1 The RCP-TX7 includes CCA-7-5 cable. *2 The A-8278-057-A bracket (service part) is required to mount on the DSR-570WS/370. *3 The recommended use for the BP-L40A is 30 W or less. *4 The connector on one end of the cable has a locking mechanism, and is attached to a i.LINK connector with the same locking mechanism, such as the DSR-570WS.</p>		

Specifications

General		DSR-570WS	DSR-570WSP	DSR-370	DSR-370P
Power requirements		DC 12 V (11 to 17 V)		DC 12 V (11 to 17 V)	
Power consumption		24 W (without VF), 26.1 W (with VF)		20 W (without VF), 22.1 W (with VF)	
Operating temperature		0 °C to 40 °C (32 °F to 104 °F)			
Storage temperature		-20 °C to 60 °C (-4 °F to 140 °F)			
Operating humidity		Less than 85%			
Storage humidity		Less than 90%			
Tape speed		28.193 mm/s	28.221 mm/s	28.193 mm/s	28.221 mm/s
Recording/Playback time	Standard size	184 min. with PDV184ME			
	Mini size	40 min. with PDVM40ME			
Fast forward/Rewind time	Standard size	Approx. 12 min. with PDV184ME			
	Mini size	Approx. 3 min. with PDVM40ME			
Continuous recording time		Approx. 70 min. with BP-L40/40A, 90 min. with BP-M50, 140 min. with BP-L60A, 200 min. with BP-M100, 230 min. with BP-L90A.		Approx. 80 min. with BP-L40/40A, 100 min. with BP-M50A, 180 min. with BP-L60A, 230 min. with BP-M100, 290 min. with BP-L90A.	
Weight		Approx. 14.1 lb 225.7 oz (6.4 kg) with VF, microphone, lens (VCL-919BX), battery (BP-L40A) and miniDV tape		Approx. 6.2 kg (13.6 lb, 218.6 oz) with VF, microphone, lens (VCL-719BX), battery (BP-L40A) and miniDV tape	
Dimensions (w/h/d)		4 7/8 x 7 5/8 x 11 1/8 inches (121 x 192 x 280 mm) (without projections) 9 5/8 x 9 3/4 x 21 1/2 inches (242 x 247 x 547 mm) (with projections)		121 x 192 x 270 mm (4 7/8 x 7 5/8 x 10 3/4 inches) (without projections) 242 x 247 x 536 mm (9 5/8 x 9 3/4 x 21 1/8 inches) (with projections)	
Camera					
Image device		3-chip 2/3-inch type, Interline-Transfer CCD		3-chip 1/2-inch type, Interline-Transfer CCD	
Optics		F1.4 medium index prism system			
Effective picture elements		980 x 494 (H x V)	980 x 582 (H x V)	768 x 494 (H x V)	752 x 582 (H x V)
Total picture elements		1038 x 504 (H x V)	1038 x 594 (H x V)	811 x 508 (H x V)	795 x 596 (H x V)
Sensing area		9.6 mm x 5.4 mm		6.4 mm x 4.8 mm	
Built-in filters		1: 3200 K, 2: 5600 K+1/8 ND, 3: 5600 K, 4: 5600 K+1/64 ND			
Lens mount		Sony 2/3-inch type Bayonet mount		Sony 1/2-inch type Bayonet mount	
Signal system		NTSC color system	PAL color system	NTSC color system	PAL color system
Scanning system		2:1 interlaced, 525 lines, 60 fields/s	2:1 interlaced, 625 lines, 50 fields/s	2:1 interlaced, 525 lines, 60 fields/s	2:1 interlaced, 625 lines, 50 fields/s
Horizontal frequency		15,734 kHz	15,625 kHz	15,734 kHz	15,625 kHz
Vertical frequency		59.94 Hz	50 Hz	59.94 Hz	50 Hz
Sync system		Internal Sync, GENLOCK IN/VIDEO IN (VBS or BS) External Sync, VTR/CCU IN			
Horizontal resolution		16:9 mode : 800 TV lines (center), 4:3 mode : 850 TV lines (center)		800 TV lines (center)	
Vertical resolution		400 TV lines (without EVS), 450 TV lines (with EVS)	480 TV lines (without EVS), 530 TV lines (with EVS)	400 TV lines (without EVS), 450 TV lines (with EVS)	480 TV lines (without EVS), 530 TV lines (with EVS)
Minimum illumination		0.25 lx with F1.4, Hyper gain (42 dB) 0.4 lx with F1.8, Hyper gain (42 dB)		0.5 lx with F1.4, Hyper gain (36 dB) 0.8 lx with F1.8, Hyper gain (36 dB)	
Sensitivity		F1.1 at 2000 lx (3200 K, 89.9 % reflectance) (typical)			
Gain selection		-3 dB, 0 dB, 3 dB, 6 dB, 9 dB, 12 dB, 18 dB, 24 dB+DPR,* 24 dB, 24 dB+DPR, Hyper Gain (36 dB or 42 dB selectable)		-3 dB, 0 dB, 3 dB, 6 dB, 9 dB, 12 dB, 18 dB, 24 dB+DPR,* 24 dB, 24 dB+DPR, Hyper Gain (36 dB)	
Shutter speed selection		OFF, 1/100, 1/250, 1/500, 1/1000, 1/2000 (s)	OFF, 1/60, 1/250, 1/500, 1/1000, 1/2000 (s)	OFF, 1/100, 1/250, 1/500, 1/1000, 1/2000 (s)	OFF, 1/60, 1/250, 1/500, 1/1000, 1/2000 (s)
Clear scan selection		60.4 to 200.3 Hz	50.3 to 201.4 Hz	60.4 to 200.3 Hz	50.3 to 201.4 Hz
Signal-to-noise ratio		63 dB (typical)	61 dB (typical)	62 dB (typical)	60 dB (typical)
Registration		0.05% (all zones, without lens)			
Geometric distortion		Below measurable level			
VTR					
VIDEO PERFORMANCE**					
Bandwidth	Luminance	30 Hz to 5.0 MHz ± 1.0 dB	25 Hz to 5.5 MHz +1.0/-2.0 dB	30 Hz to 5.0 MHz ± 1.0 dB	25 Hz to 5.5 MHz +1.0/-2.0 dB
	Chrominance	30 Hz to 1.5 MHz +1.0/-5.0 dB	25 Hz to 2.0 MHz +1.0/-2.0 dB	30 Hz to 1.5 MHz +1.0/-5.0 dB	25 Hz to 2.0 MHz +1.0/-2.0 dB
S/N ratio (luminance)		More than 55 dB			
K-factor (K2T, KP8)		Less than 2.0%			
Y/C delay		Less than 30 nsec			
AUDIO PERFORMANCE**					
Frequency response	48 KHz	20 Hz to 20 kHz +0.5/-1.0 dB			
	32 KHz	20 Hz to 14.5 KHz +0.5/-1.0 dB			
Dynamic range		More than 80 dB			
Distortion (THD)		Less than 0.08% (1 kHz reference level, 48 kHz)			
INPUT/OUTPUT					
Signal inputs	GENLOCK VIDEO IN	BNC, 1.0 Vp-p, 75 Ω			
	TC IN	BNC, 0.5 Vp-p to 18 Vp-p, 10 kΩ			
	EXT AUDIO CH-1/2	XLR 3-pin x 2 Female, -60 dBu, 3 kΩ/+4 dBu, 10 kΩ			
	MIC IN	XLR 3-pin Female			
	ANALOG VIDEO IN	BNC, 1.0 Vp-p, 75 Ω (When the option board DSBK-501 is installed.)			
Signal outputs	VIDEO OUT	BNC, 1.0 Vp-p, sync negative, 75 Ω, 26-pin Male			
	VBS	1.0 Vp-p, sync negative			
	Y/R-Y/B-Y	Y: 1.0 Vp-p, sync negative R-Y/B-Y: 700 mVp-p	Y: 1.0 Vp-p, sync negative R-Y/B-Y: 525 mVp-p	Y: 1.0 Vp-p, sync negative R-Y/B-Y: 700 mVp-p	Y: 1.0 Vp-p, sync negative R-Y/B-Y: 525 mVp-p
	Y/C	Y: 1.0 Vp-p, sync negative C: 286 mVp-p (burst level)	Y: 1.0 Vp-p, sync negative C: 300 mVp-p (burst level)	Y: 1.0 Vp-p, sync negative C: 286 mVp-p (burst level)	Y: 1.0 Vp-p, sync negative C: 300 mVp-p (burst level)
	DV OUT	i.LINK, 6-pin IEEE1394-based			
	MONITOR OUT	BNC, 1.0 Vp-p, sync negative, 75 Ω			
	TC OUT	BNC, 1.0 Vp-p, 75 Ω			
	AUDIO CH-1/2	RCA pin, -10 dBu, 47 kΩ			
	S-VIDEO	DIN 4-pin, 1.0 Vp-p, 75 Ω			
Others	DC IN	XLR 4-pin, Male			
	DC OUT	4-pin, Female			
	BATTERY TERMINAL	5-pin			
	EARPHONE	Mini-jack			
	LIGHT OUT	2-pin Female			
	WRR OUT	7-pin			
	LENS	12-pin			
	VF	20-pin			
	REMOTE1	Stereo mini			
	REMOTE2	10-pin			

* DPR is equivalent to +6 dB gain up. ** The above VIDEO/AUDIO PERFORMANCE specifications were measured by playing back material recorded by each camcorder on a DSR-1800/1800P (via analog component out for video), 0 dBu = 0.775 Vrms

VCL-716BX (for DSR-370K2 pack)	
Zoom ratio	16:1
Focal length	7.3mm to 117mm
Zoom control	Servo/manual switchable
Iris control	Servo/manual switchable
Maximum relative aperture	F1.9 (7.3 to 98mm) to F2.3 (117mm)
Minimum object distance	Wide: 823 x 617mm, Tele: 51 x 39mm
Mount type	Sony 1/2-inch type bayonet mount
Weight	1.2kg (including lens hood)
Dimensions (WxHxD)	123 x 102 x 205mm (including obstructions)

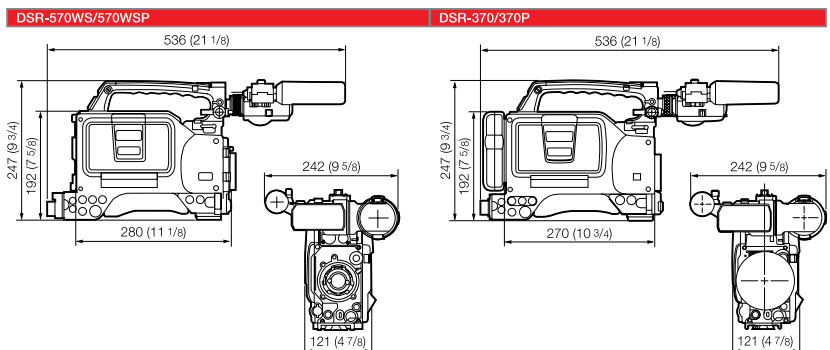

SONY[®]

Sony Electronics Inc.
One Sony Drive
Park Ridge, NJ 07656
www.sony.com/professional

© 2002 Sony Corporation. All rights reserved.

Reproduction in whole or in part without written permission is prohibited.
Features, design and specifications are subject to change without notice.

All non-metric weights and measures are approximate.

Sony, Clear Scan, ClipLink, DVCAM logo, DynaFit, DynaLatitude, EditStation, i.LINK,
Power HAD, Power HAD WS, SetupLog, SetupNavi and TruEye are trademarks
of Sony Corporation.

All other trademarks are the property of their respective owners.