

LCD Monitor

Operating Instructions



LMD-9050
LMD-9030
LMD-9020

English

Owner's Record

The model and serial numbers are located at the rear. Record these numbers in the spaces provided below. Refer to these numbers whenever you call upon your Sony dealer regarding this product.

Model No. _____

Serial No. _____

WARNING

To reduce the risk of fire or electric shock, do not expose this apparatus to rain or moisture.

Dangerously high voltages are present inside the unit. Do not open the cabinet. Refer servicing to qualified personnel only.

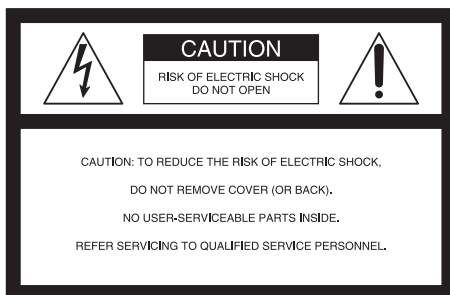

This symbol is intended to alert the user to the presence of uninsulated "dangerous voltage" within the product's enclosure that may be of sufficient magnitude to constitute a risk of electric shock to persons.



This symbol is intended to alert the user to the presence of important operating and maintenance (servicing) instructions in the literature accompanying the appliance.

In the event of a malfunction or when maintenance is necessary, consult an authorized Sony dealer.

Warning on power connection

Use a proper power cord for your local power supply.

	The United States, Canada	Continental Europe	UK, Ireland, Australia, New Zealand
Plug type	VM0233	COX-07/636	- 1)
Female end	VM0089	COX-02/VM0310B	VM0303B
Cord type	SVT	H05VV-F	CEE(13)53rd (O, C)
Rated Voltage & Current	10A/125V	10A/250V	10A/250V
Safety approval	UL/CSA	VDE	VDE

1) Use an appropriate rating plug which is applied to local regulations.

This unit contains substances which can pollute the environment if disposed carelessly. Please contact our nearest representative office or your local environmental office in case of disposal of this unit.

WARNING THIS APPARATUS MUST BE EARTHED.

WARNING

This unit has no primary power switch. When installing the unit, incorporate a readily accessible disconnect device in the fixed wiring, or connect the power cord to socket-outlet which must be provided near the unit and easily accessible. If a fault should occur during operation of the unit, operate the disconnect device to switch the power supply off, or disconnect the power cord.

For the customers in Europe

This product with the CE marking complies with both the EMC Directive (89/336/EEC) and the Low Voltage Directive (73/23/EEC) issued by the Commission of the European Community.

Compliance with these directives implies conformity to the following European standards:

- EN60950-1: Product Safety
- EN55103-1: Electromagnetic Interference (Emission)
- EN55103-2: Electromagnetic Susceptibility (Immunity)

This product is intended for use in the following Electromagnetic Environment(s):

E1 (residential), E2 (commercial and light industrial), E3 (urban outdoors), E4 (controlled EMC environment, ex. TV studio).

For the Customers in the USA

This equipment has been tested and found to comply with the limits for a Class A digital device, pursuant to Part 15 of the FCC Rules. These limits are designed to provide reasonable protection against harmful interference when the equipment is operated in a commercial environment. This equipment generates, uses, and can radiate radio frequency energy and, if not installed and used in accordance with the instruction manual, may cause harmful interference to radio communications. Operation of this equipment in a residential area is likely to cause harmful interference in which case the user will be required to correct the interference at his own expense.

You are cautioned that any changes or modifications not expressly approved in this manual could void your authority to operate this equipment.

All interface cables used to connect peripherals must be shielded in order to comply with the limits for a digital device pursuant to Subpart B of Part 15 of FCC Rules.

For the customers in the USA

This product (fluorescent lamp in the liquid crystal display) contains mercury. Disposal of this product may be regulated if sold in the United States. For disposal or recycling information, please contact your local authorities or the Electronics Industries Alliance (www.eiae.org <http://www.eiae.org>)

For the customers in the USA and Canada

RECYCLING LITHIUM-ION BATTERIES

Lithium-Ion batteries are recyclable.

You can help preserve our environment by returning your used rechargeable batteries to the collection and recycling location nearest you.

For more information regarding recycling of rechargeable batteries, call toll free 1-800-822-8837, or visit <http://www.rbrcc.org/>

Caution: Do not handle damaged or leaking Lithium-Ion batteries.



Voor de Klanten in Nederland

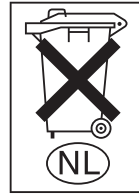

Gooi de batterij niet weg maar lever deze in als klein chemisch afval (KCA).

Attention-when the product is installed in Rack:

1.Prevention against overloading of branch circuit

When this product is installed in a rack and is supplied power from an outlet on the rack, please make sure that the rack does not overload the supply circuit.

2.Providing protective earth

When this product is installed in a rack and is supplied power from an outlet on the rack, please confirm that the outlet is provided with a suitable protective earth connection.

3.Internal air ambient temperature of the rack

When this product is installed in a rack, please make sure that the internal air ambient temperature of the rack is within the specified limit of this product.

4.Prevention against achieving hazardous condition due to uneven mechanical loading

When this product is installed in a rack, please make sure that the rack does not achieve hazardous condition due to uneven mechanical loading.

5.Install the equipment while taking the operating temperature of the equipment into consideration

Please ensure the amount of air flow required for safe operation of this product.

For the operating temperature of the equipment, refer to the specifications of the Operation Manual.

Important Safety Instructions

- Read these instructions.
- Keep these instructions.
- Heed all warnings.
- Follow all instructions.
- Do not use this apparatus near water.
- Clean only with dry cloth.
- Do not block any ventilation openings. Install in accordance with the manufacturer's instructions.
- Do not install near any heat sources such as radiators, heat registers, stoves, or other apparatus (including amplifiers) that produce heat.
- Do not defeat the safety purpose of the polarized or grounding-type plug. A polarized plug has two blades with one wider than the other. A grounding type plug has two blades and a third grounding prong. The wide blade or the third prong are provided for your safety. If the provided plug does not fit into your outlet, consult an electrician for replacement of the obsolete outlet.
- Protect the power cord from being walked on or pinched particularly at plugs, convenience receptacles, and the point where they exit from the apparatus.
- Only use attachments/accessories specified by the manufacturer.
- Use only with the stand or bracket specified by the manufacturer, or sold with the apparatus.
- Unplug this apparatus during lightning storms or when unused for long periods of time.
- Refer all servicing to qualified service personnel. Servicing is required when the apparatus has been damaged in any way, such as power-supply cord or plug is damaged, liquid has been spilled or objects have fallen into the apparatus, the apparatus has been exposed to rain or moisture, does not operate normally, or has been dropped.

AVERTISSEMENT

Afin de réduire les risques d'incendie ou d'électrocution, ne pas exposer cet appareil à la pluie ou à l'humidité.

Des courants de hautes tensions dangereuses sont présents à l'intérieur de cet appareil. Ne pas ouvrir le coffret. Confier l'entretien de cet appareil exclusivement à un personnel qualifié.

Dans le cas d'une défaillance ou de nécessité d'entretien, consulter un revendeur Sony autorisé.

Cet appareil contient des substances susceptibles de causer une pollution de l'environnement si elles sont éliminées de façon non conforme. Consultez votre bureau local de préservation de l'environnement pour savoir comment vous débarrasser de cet appareil.

**AVERTISSEMENT
CET APPAREIL DOIT ETRE RELIE A LA TERRE.**

AVERTISSEMENT

Cet appareil ne dispose pas d'un commutateur d'alimentation principal.

Lorsque vous installez l'appareil, incorporez un dispositif de déconnexion accessible dans le câblage fixe ou branchez le cordon d'alimentation à une prise de courant située près de l'appareil et facilement accessible.

En cas d'incident pendant le fonctionnement de l'appareil, actionnez le dispositif de déconnexion afin de le mettre hors tension ou débranchez le cordon d'alimentation.

Pour les clients européens

Ce produit portant la marque CE est conforme à la fois à la Directive sur la compatibilité électromagnétique (EMC) (89/336/CEE) et à la Directive sur les basses tensions (73/23/CEE) émises par la Commission de la Communauté européenne.

La conformité à ces directives implique la conformité aux normes européennes suivantes :

- EN60950-1 : Sécurité des produits
- EN55103-1 : Interférences électromagnétiques (émission)
- EN55103-2 : Sensibilité électromagnétique (immunité)

Ce produit est prévu pour être utilisé dans les environnements électromagnétiques suivants : E1 (résidentiel), E2 (commercial et industrie légère), E3 (urbain extérieur) et E4 (environnement EMC contrôlé ex. studio de télévision).

Pour les utilisateurs aux Etats-Unis et au Canada.**RECYCLAGE DES ACCUMULATEURS AUX IONS DE LITHIUM**

Les accumulateurs aux ions de lithium sont recyclables. Vous pouvez contribuer à préserver l'environnement en rapportant les piles usées dans un point de collection et recyclage le plus proche.

Pour plus d'informations sur le recyclage des accumulateurs, téléphonez le numéro gratuit 1-800-822-8837 (Etats-Unis et Canada uniquement), ou visitez <http://www.rbrc.org/>

Avertissement: Ne pas utiliser des accumulateurs aux ions de lithium qui sont endommagés ou qui fuient.

**Avertissement concernant le raccordement au secteur**

Utilisez un cordon d'alimentation adapté à la tension secteur.

	Etats-Unis, Canada	Europe continentale	Royaume-Uni, Irlande, Australie, Nouvelle-Zélande
Type de fiche	VM0233	COX-07/636	- 1)
Extrémité femelle	VM0089	COX-02/VM0310B	VM0303B
Type de cordon	SVT	H05VV-F	CEE(13)53rd (O, C)
Intensité et tension nominales	10A/125V	10A/250V	10A/250V
Certification de sécurité	UL/CSA	VDE	VDE

1) Utilisez une fiche présentant les valeurs nominales appropriées et conforme à la réglementation locale en vigueur.

WARNUNG

Um die Gefahr von Bränden oder elektrischen Schlägen zu verringern, darf dieses Gerät nicht Regen oder Feuchtigkeit ausgesetzt werden.

Im Inneren des Geräts liegen sehr hohe Spannungen an. Öffnen Sie das Gehäuse nicht. Überlassen Sie Wartungsarbeiten stets nur qualifiziertem Fachpersonal.

Sollten am Gerät Probleme auftreten oder eine Wartung erforderlich werden, wenden Sie sich an einen autorisierten Sony -Händler.

Dieses Gerät enthält Substanzen, die bei unsachgemäßer Entsorgung die Umwelt belasten. Bitten wenden Sie sich an unsere nächste Niederlassung oder an Ihr Umweltschutzamt, wenn Sie das Gerät entsorgen wollen.

**WARNUNG
DIESES GERÄT MUSS GEERDET WERDEN.**

WARNUNG

Dieses Gerät verfügt über keinen Hauptnetzschalter. Fügen Sie beim Einbau des Geräts einen leicht zugänglichen Schalter in die Verkabelung ein oder verbinden Sie das Netzkabel mit einer leicht zugänglichen Steckdose in der Nähe des Geräts. Wenn beim Betrieb des Geräts ein Fehler auftritt, können Sie mit dem Schalter die Spannungsversorgung unterbrechen oder den Stecker ziehen.

Warnhinweis zum Netzanschluss

Verwenden Sie ein für die Stromversorgung in Ihrem Land geeignetes Netzkabel.

	USA, Kanada	Kontinental-Europa	Großbritannien, Irland, Australien, Neuseeland
Steckertyp	VM0233	COX-07/636	- 1)
Buchse	VM0089	COX-02/VM0310B	VM0303B
Kabeltyp	SVT	H05VV-F	CEE(13)53rd (O, C)
Nennspannung & Stromstärke	10A/125V	10A/250V	10A/250V
Sicherheitszertifizierung	UL/CSA	VDE	VDE

1) Verwenden Sie einen geeigneten Netzstecker, der die örtlichen Bestimmungen erfüllt.

Für Kunden in Europa

Dieses Produkt besitzt die CE-Kennzeichnung Und erfüllt die EMV-Richtlinie (89/336/EWG) sowie die Niederspannungsrichtlinie (73/23/EWG) der EG-Kommission.

Angewandte Normen:

- EN60950-1: Sicherheitsbestimmungen
- EN55103-1: Elektromagnetische Verträglichkeit (Störaussendung)
- EN55103-2: Elektromagnetische Verträglichkeit (Störfestigkeit),

Dieses Produkt ist für den Einsatz unter folgenden elektromagnetischen Bedingungen ausgelegt: E1 (Wohnbereich), E2 (kommerzieller und in beschränktem Maße industrieller Bereich), E3 (Stadtbereich im Freien) und E4 (kontrollierter EMV-Bereich, z. B. Fernsehstudio).

Für Kunden in Deutschland

Entsorgungshinweis: Bitte werfen Sie nur entladene Batterien in die Sammelboxen beim Handel oder den Kommunen. Entladen sind Batterien in der Regel dann, wenn das Gerät abschaltet und signalisiert „Batterie leer“ oder nach längerer Gebrauchsdauer der Batterien „nicht mehr einwandfrei funktioniert“. Um sicherzugehen, kleben Sie die Batteriepole z.B. mit einem Klebestreifen ab oder geben Sie die Batterien einzeln in einen Plastikbeutel.

ATTENZIONE

Per ridurre il rischio di incendi o scosse elettriche, non esporre questo apparato alla pioggia o all'umidità.

All'interno dell'apparecchio sono presenti tensioni pericolosamente alte. Non aprire l'apparecchio. Per le riparazioni rivolgersi esclusivamente a personale qualificato.

Nel caso di malfunzionamenti o di necessarie riparazioni dell'apparecchio, consultare un rivenditore autorizzato Sony.

Questo apparecchio contiene sostanze che possono inquinare l'ambiente se non vengono smaltite con le dovute cautele. Per informazioni sulle normative in caso di smaltimento di questo apparecchio, si prega di contattare il nostro rappresentante locale o il centro di informazioni ambientali di zona.

**AVVERTENZA
QUESTO APPARECCHIO DEVE ESSERE COLLEGATO A MASSA.**

ATTENZIONE

Questo apparecchio non è dotato di un interruttore di alimentazione primaria.

Durante l'installazione dell'apparecchio, incorporare un dispositivo di scollegamento prontamente accessibile nel cablaggio fisso, oppure collegare il cavo di alimentazione alla presa di corrente, che dovrà trovarsi nei pressi dell'apparecchio ed essere facilmente accessibile.

Qualora si verifichi un guasto durante il funzionamento dell'apparecchio, azionare il dispositivo di scollegamento per interrompere il flusso di corrente oppure scollegare il cavo di alimentazione.

Per i clienti in Europa

Questo prodotto recante il marchio CE è conforme sia alla direttiva sulla compatibilità elettromagnetica (EMC) (89/336/CEE) che alla direttiva sulle basse tensioni (73/23/CEE) emesse dalla Commissione della Comunità Europea.

La conformità a queste direttive implica la conformità alle seguenti normative europee:

- EN60950-1: Sicurezza dei prodotti
- EN55103-1: Interferenza elettromagnetica (Emissione)
- EN55103-2: Sensibilità ai disturbi elettromagnetici (Immunità)

Il presente prodotto è stato progettato per l'impiego in uno o più dei seguenti ambienti elettromagnetici: E1 (residenziale), E2 (commerciale e di industria leggera), E3 (esterni urbani) e E4 (ambiente controllato EMC, ad esempio uno studio televisivo).

Avvertenza sul collegamento dell'alimentazione

Utilizzare un cavo di alimentazione adeguato all'alimentazione del Paese in cui ci si trova.

	Stati Uniti, Canada	Europa continentale	Regno Unito, Irlanda, Australia, Nuova Zelanda Giappone
Tipo di spina	VM0233	COX-07/636	- 1)
Terminale femmina	VM0089	COX-02/VM0310B	VM0303B
Tipo di cavo	SVT	H05VV-F	CEE(13)53rd (O, C)
Tensione e corrente nominale	10A/125V	10A/250V	10A/250V
Approvazione di sicurezza	UL/CSA	VDE	VDE

1) Utilizzare una presa con voltaggio adeguato conforme alle normative locali.

ADVERTENCIA

Para reducir el riesgo de incendio o de electrocución, no exponga este aparato a la lluvia ni a la humedad.

En el interior de la unidad hay presente alta tensión. No abra la unidad. Solicite asistencia técnica únicamente a personal especializado.

En caso de mal funcionamiento o cuando sea necesario el servicio de mantenimiento, consulte a su proveedor Sony.

Esta unidad contiene sustancias que pueden contaminar el medio ambiente si no se desecha adecuadamente. Póngase en contacto con nuestro departamento de representación más próximo o con el departamento local de medio ambiente cuando vaya a desechar esta unidad.

**ADVERTENCIA
ESTE APARATO DEBE CONECTARSE A TIERRA.**

ADVERTENCIA

Esta unidad no dispone de interruptor de alimentación primario.

Al instalar la unidad, incluya un dispositivo de desconexión fácilmente accesible en el cableado fijo, o conecte el cable de alimentación a una toma de corriente que debe estar cerca de la unidad y ser de fácil acceso. Si se produce una anomalía durante el funcionamiento de la unidad, accione el dispositivo de desconexión para desactivar la alimentación o desconecte el cable de alimentación.

Advertencia sobre la conexión de alimentación

Utilice un cable de alimentación adecuado al suministro eléctrico local.

	Estados Unidos y Canadá	Europa continental	Reino Unido, Irlanda, Australia y Nueva Zelanda
Tipo de enchufe	VM0233	COX-07/636	_ 1)
Extremo hembra	VM0089	COX-02/VM0310B	VM0303B
Tipo de cable	SVT	H05VV-F	CEE(13)53rd (O, C)
Corriente y tensión nominal	10A/125V	10A/250V	10A/250V
Aprobación de seguridad	UL/CSA	VDE	VDE

1) Utilice un enchufe de valor nominal adecuado que cumpla con la normativa local.

Para los usuarios en Europa

Este producto con la marca CE cumple con las Directivas EMC (89/336/CEE) y de Baja Tensión (73/23/CEE) emitidas por la Comisión de la Comunidad Europea.

El cumplimiento de estas directivas implica la conformidad con los siguientes estándares europeos:

- EN60950-1: Seguridad del producto
- EN55103-1: Interferencias electromagnéticas (Emisión)
- EN55103-2: Susceptibilidad electromagnética (Inmunidad)

Este producto está diseñado para utilizarse en los siguientes entornos electromagnéticos:

E1 (residencial), E2 (comercial e industria ligera), E3 (exteriores urbanos) y E4 (entorno de EMC controlada, ej. estudio de TV).

Para clientes de los EE UU y CANADÁ RECYCLADO DE BATERÍAS DE IONES DE LITIO

Las baterías de iones de litio son reciclables.

Usted podrá ayudar a conservar el medio ambiente devolviendo las baterías usadas al punto de reciclaje más cercano.

Para más información sobre el reciclado de baterías, llame al número gratuito 1-800-822-8837, o visite <http://www.rbrc.org/>

Precaución: No utilice baterías de iones de litio dañadas o con fugas.



中文

警告

为减少火灾或电击危险，请勿让本设备受到雨淋或受潮。

设备内带有危险高压。请勿拆卸机壳。维修事宜应仅由合格维修人员进行。

在发生故障或需要维修时，请与经授权的 Sony 经销商联络。

本机带有有害物质，废弃时若处理不当会污染环境。废弃本机时，请就近与本公司办事处或贵地环境管理部门联系。

警告

此设备必须完好接地。

关于电源连接的警告

请使用符合贵地电源的电源线

警告

此设备没有主电源开关。

当连接此设备时，请在固定布线中使用一个容易操作的断路设备，或者将电源线连接到设备附近易于使用的电源插座上。

如果在设备工作中发生故障，操作断路设备关闭电源，或者断开电源线。

中文

警告

若要降低起火或觸電的風險，請勿將本裝置曝露在雨中或潮濕環境中。

機器內部有危險高電壓。請勿開啓機殼。請僅由合格的維修人員進行維修。

警告
本裝置必須接地。

電源連接警告
使用符合當地電源的電源線。

警告
本裝置無主要電源開關。
當安裝本裝置時，請連接可容易取得的固定配線中斷連接裝置，或將電源線連接至靠近裝置且可容易取得的插槽插座。
如果在裝置運作期間發生故障時，請操作中斷連接裝置，以便將電源關閉，或拔下電源線。

For the customers in Taiwan only



廢電池請回收

경고

화재나 감전 위험을 줄이려면 이 장치가 물기나 습기에 노출되지 않도록 하십시오.

장치 내부에는 고압이 사용되므로 위험합니다. 절대 본체를 열지 마십시오. 자격 있는 전문 정비 요원만 서비스를 실시해야 합니다.

경고

이 장치는 접지되어야만 합니다.

전원 연결에 대한 경고

현지 공급 전원에 맞는 규격 전원 코드를 사용하십시오.

경고

이 기기에는 기본 전원 스위치가 없습니다. 기기를 설치할 때는 접근이 용이한 스위치를 고정된 배선에 만들어 사용하거나 벽면 콘센트에 전원 코드를 연결해야 하며, 이때 콘센트는 기기 근처에 있어야 하고 접근이 용이해야 합니다. 기기를 조작하는 동안 오류가 발생하면 스위치를 작동하여 전원을 끄거나 전원 코드를 뽑으십시오.

Table of Contents

Precaution	13
On Safety	13
On Installation	13
Handling the LCD Screen	13
About the Fluorescent Tube	13
On Cleaning	13
On Repacking	13
On Mounting on a Rack	14
On Fan Error	14
Features	14
Location and Function of Parts and Controls ..	16
Front Panel	16
Input Signals and Adjustable/Setting Items	18
Rear Panel	19
Installing to the Rack	21
Power Sources	21
Attaching the AC Adaptor or Battery Pack	21
Connecting the AC Power Cord	22
Selecting the Default Settings	22
Selecting the Menu Language	24
Using the Menu	25
Adjustment Using the Menus	26
Items	26
Adjusting and Changing the Settings	27
STATUS menu.....	27
COLOR TEMP/BAL menu	27
USER CONTROL menu.....	27
USER CONFIG menu.....	28
REMOTE PARALLEL menu.....	31
KEY INHIBIT menu.....	31
Troubleshooting	32
Specifications	32
Dimensions	36

Precaution

On Safety

- Operate the unit only with a power source as specified in the “Specifications” section.
- A nameplate indicating operating voltage, power consumption, etc., is located on the bottom.
- Should any solid object or liquid fall into the cabinet, unplug the unit and have it checked by qualified personnel before operating it any further.
- Do not drop or place heavy objects on the power cord. If the power cord is damaged, turn off the power immediately. It is dangerous to use the unit with a damaged power cord.
- Unplug the unit from the wall outlet if it is not to be used for several days or more.
- Disconnect the power cord from the AC outlet by grasping the plug, not by pulling the cord.
- The socket-outlet shall be installed near the equipment and shall be easily accessible.

On Installation

- Allow adequate air circulation to prevent internal heat build-up.
Do not place the unit on surfaces (rugs, blankets, etc.) or near materials (curtains, draperies) that may block the ventilation holes.
- Do not install the unit in a location near heat sources such as radiators or air ducts, or in a place subject to direct sunlight, excessive dust, mechanical vibration or shock.

Handling the LCD Screen

- Bright or dark points of lights (red, blue or green) may appear on the LCD screen. This is not a malfunction. The LCD screen is made with high-precision technology with more than 99.99 % of the picture elements intact. However, some picture elements may not appear intermittently.
- Do not leave the LCD screen facing the sun as it can damage the LCD screen. Take care when you place the unit by a window.
- Do not push or scratch the LCD monitor’s screen. Do not place a heavy object on the LCD monitor’s screen. This may cause the screen to lose uniformity.
- If the unit is used in a cold place, horizontal lines or a residual image may appear on the screen. This is not a malfunction. When the monitor becomes warm, the screen returns to normal.

- If a still picture is displayed for a long time, a residual image may appear. The residual image will eventually disappear.
- The screen and the cabinet become warm during operation. This is not a malfunction.

About the Fluorescent Tube

A specially designed fluorescent tube is installed as the lighting apparatus for this unit. If the LCD screen becomes dark, unstable or does not turn on, consult your Sony dealer.

On Cleaning

Before cleaning

Be sure to disconnect the AC power cord from the AC outlet.

On cleaning the monitor screen

The monitor screen surface is especially treated to reduce reflection of light.

As incorrect maintenance may impair the performance of the monitor, take care with respect to the following:

- Wipe the screen gently with a soft cloth such as a cleaning cloth or glass cleaning cloth.
- Stubborn stains may be removed with a soft cloth such as a cleaning cloth or glass cleaning cloth lightly dampened with water.
- Never use solvent such as alcohol, benzene or thinner, or acid, alkaline or abrasive detergent, or chemical cleaning cloth, as they will damage the screen surface.

On cleaning the cabinet

- Clean the cabinet gently with a soft dry cloth. Stubborn stains may be removed with a cloth lightly dampened with mild detergent solution, followed by wiping with a soft dry cloth.
- Use of alcohol, benzene, thinner or insecticide may damage the finish of the cabinet or remove the indications on the cabinet. Do not use these chemicals.
- If you rub on the cabinet with a stained cloth, the cabinet may be scratched.
- If the cabinet is in contact with a rubber or vinyl resin product for a long period of time, the finish of the cabinet may deteriorate or the coating may come off.

On Repacking

Do not throw away the carton and packing materials. They make an ideal container which to transport the unit.

On Mounting on a Rack

Leave 1U space empty above and below the monitor to ensure adequate air circulation or install a fan to maintain the monitor's performance.

If you have any questions about this unit, contact your authorized Sony dealer.

On Fan Error

The fan for cooling the unit is built in. When the "FAN ERROR" message is displayed, turn off the power and contact an authorized Sony dealer.

Features

High brightness LCD panel

Because of the monitor's high brightness, high contrast and wide viewing angle technology, it can be used under various lighting conditions. Use the light intercepting hood, connector protector and carrying handle (optional Sony VF-509 monitor ENG kit) for outdoor use.

Rack mount monitors

The LMD-9050, LMD-9030 and LMD-9020 can be installed in a standard 19-inch rack using an optional rack mounting bracket MB-525. This is essential when space is paramount in crowded OB vehicles.

Monitor stand

You can set the monitor display in 90 degrees by using the stand.

Lightweight, thin design/AC power adaptor mount function

The lightweight, thin design reduces the load for an OB vehicle and the space needed for the equipment. Also, an AC power adaptor can be installed to the rear of the monitor for easy use.

3-color tally lamp

The tally lamp lights in red, green or amber to monitor each input picture and check the on-air mode.

Monaural speaker

The monitor has a monaural speaker to reproduce sound.

Two color systems available

The monitor can display NTSC and PAL signals by connecting this unit. The appropriate color system is selected automatically.

Blue only mode

In the blue only mode, the blue element of the input signal is displayed. This mode is convenient for chroma and phase adjustment, and for monitoring VTR noise.

SDI (HD/D1-SDI) input connectors (for LMD-9050/9030)

The HD-SDI signal (LMD-9050) or D1-SDI signal (LMD-9050/9030) of the video equipment is input.

Analog RGB/component input connectors

Analog RGB or component signals from video equipment can be input through these connectors.

Y/C input connectors

The video signal, split into the luminance signal (Y) and the chrominance signal (C), can be input through this connector.

External sync input

When the EXT SYNC button is in the on position, the unit can be operated on the sync signal supplied from an external sync generator.

Automatic termination (connector with mark only)

The input connector is terminated internally at 75 ohms when nothing has been connected to the output connector. If a cable is connected to the output connector, the internal terminal is automatically released and the signals input to the input connector are output to the output connector (loop-through).

Select color temperature and gamma mode

You can select the color temperature from among two (high and low) settings and gamma mode from among five settings. You can also adjust the color temperature to the appropriate setting.

Aspect setting

You can set the monitor to 4:3 or 16:9 display mode according to the input video signal.

Various markers

Displays frame boundaries such as the center marker, etc. and supports the various film aspect ratios.

Scan setting

You can set the display size to 0%/5% over scan, -3% under scan or zoom mode.

On-screen menus

You can set the appropriate settings according to the connected system by using the on-screen menus.

Key inhibit function

You can inhibit a key, function to prevent misoperation.

Select language display

You can select from seven display languages English, German, French, Italian, Spanish, Japanese and Chinese.

External remote control function

You can directly select the input signal, aspect, etc., by operating the equipment connected to the PARALLEL REMOTE terminal.

Battery operation function

You can operate this unit for about three hours with the lithium ion battery pack BP-L40A or for about four and half hours with the BP-L90A.

Location and Function of Parts and Controls

Front Panel

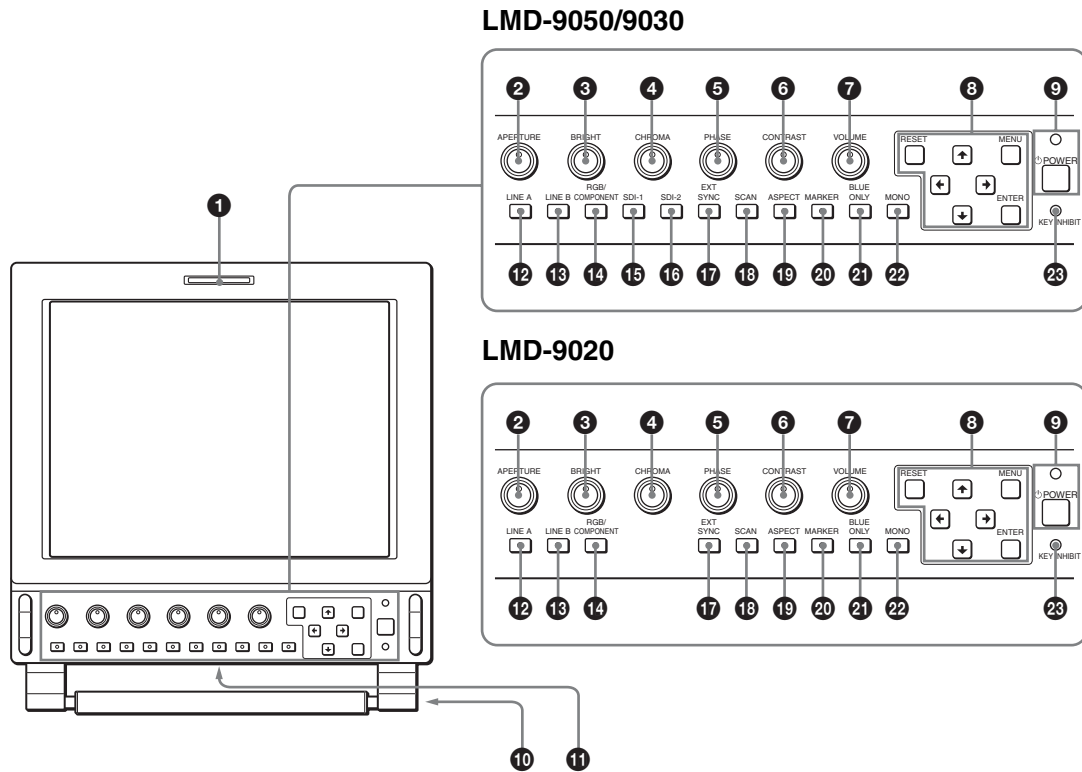

1 Tally lamp

You can check the status of the monitor by the color of the tally lamp.
The tally lamp lights in red, green or amber according to the input signals.

2 APERTURE control

Adjusts the picture sharpness.
Turn the control clockwise to increase the sharpness or counterclockwise to decrease it.

3 BRIGHT (brightness) control

Adjusts the picture brightness.
Turn the control clockwise to increase the brightness or counterclockwise to decrease it.

4 CHROMA control

Adjusts the color intensity.
Turn the control clockwise to increase the color intensity or counterclockwise to decrease it.

5 PHASE control

Adjusts color tones.
Turn the control clockwise to make the skin tones greenish or counterclockwise to make them purplish.

6 CONTRAST control

Adjusts the picture contrast.
Turn the control clockwise to make the contrast higher or counterclockwise to make it lower.

7 VOLUME control

Turn the control clockwise to increase the volume or counterclockwise to decrease it.

8 Menu operation buttons

Displays or sets the on-screen menu.

↑/↓/←/→ (arrow) buttons

Select the menu or make various adjustments.

MENU button

Press to display the on-screen menu.
Press again to clear the menu.

RESET button

Resets the value of an item back to the previous value. This button functions when the menu item is adjusted (displayed) on the screen.

ENTER button

Press to confirm a selected item on the menu.

9 POWER switch and indicator

Press to turn on the power. The indicator lights in green. Press again to turn off the power. The indicator lights in amber in power saving mode.

10 Stand

You can set the monitor display in 90 degrees by using the stand (see “Using the stand” on page 17).

11 Speaker

The audio signal which is selected by the input select button on the front panel is output. When the headphones are inserted, the sound is not output.

12 LINE A button

Press to monitor the signal through the LINE A input connectors.

13 LINE B button

Press to monitor the signal through the LINE B input connectors.

14 RGB/COMPONENT button

Press to monitor the signal through the RGB/COMPONENT input connectors.

15 SDI-1 button (for LMD-9050/9030)

Press to monitor the signal from the SDI IN-1 connector.

16 SDI-2 button (for LMD-9050/9030)

Press to monitor the signal from the SDI IN-2 connector.

17 EXT SYNC (external sync) button

Press to operate the unit on an external sync signal through the EXT SYNC IN connector. The EXT SYNC button works when the component/RGB signals are input.

18 SCAN select button

You can change the scan size of the picture. When you press the button, the scan size is changed to the normal scan (5% over scan), -3% under scan or zero scan or zoom set on the menu (see page 29).

19 ASPECT select button

Sets the aspect ratio of the picture, 4:3 or 16:9.

20 MARKER button

When the button is pressed, an area marker is displayed.

21 BLUE ONLY button

Press this button to eliminate the red and green signals. Only blue signal is displayed on the screen. This facilitates “chroma” and “phase” adjustments and observation of VCR noise.

22 MONO button

Press this button to display a monochrome picture. When the button is pressed again, the monitor switches automatically to color mode.

23 KEY INHIBIT indicator

When the key inhibit function works, the indicator lights.

For the key inhibit function, refer to “KEY INHIBIT menu” on page 31.

Using the stand

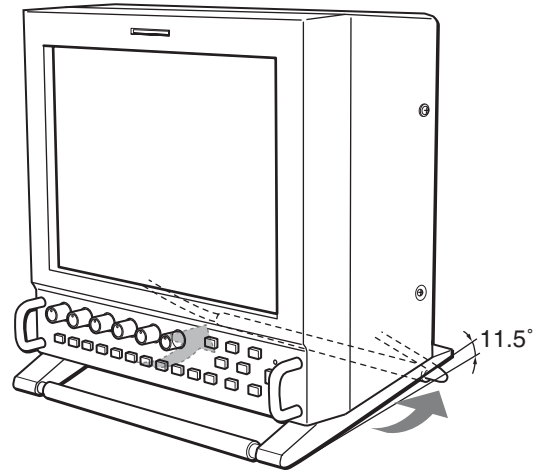

Pull out toward rear side.

Input Signals and Adjustable/ Setting Items

Item	Input signal							
	Video, Y/C	B & W	Component		RGB		SDI	
			SD	HD	SD	HD	D1* ³	HD* ⁴
CONTRAST* ¹	○	○	○	○	○	○	○	○
BRIGHT* ¹	○	○	○	○	○	○	○	○
CHROMA* ¹	○	×	○	○	×	×	○	○
PHASE* ¹	○(NTSC)	×	×	×	×	×	×	×
APERTURE	○	○	○	○	×	×	○	○
COLOR TEMP	○	○	○	○	○	○	○	○
V SHARPNESS	○	○	○	×	○	×	○	×
MATRIX* ²	×	×	○	×	×	×	×	×
COMP LEVEL	×	×	○(480/60I)	×	×	×	×	×
NTSC SETUP	○(NTSC)	○(480/60I)	×	×	×	×	×	×
GAMMA	○	○	○	○	○	○	○	○
EXT SYNC	×	×	○	○	○	○	×	×
SCAN	○	○	○	○	○	○	○	○
ASPECT	○	○	○	×	○	×	○	×
MARKER	○	○	○	○	○	○	○	○
BLUE ONLY	○	×	○	○	○	○	○	○
MONO	○	×	○	○	×	×	○	○
POWER SAVING	○	○	○	○	○	○	○	○

*1 Adjustment of SUB CONTROL is the same.

*2 When a component signal (480/60I or 480/60P) is input and the COMP LEVEL is set to SMPTE, this can be switchable.

*3 Available for LMD-9050/9030

*4 Available for LMD-9050 only

○ : Adjustable/can be set

×

Rear Panel

LMD-9020

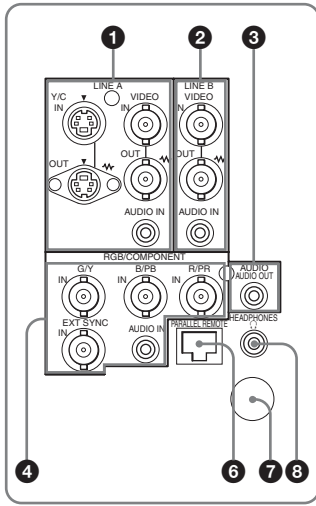

LMD-9050/9030

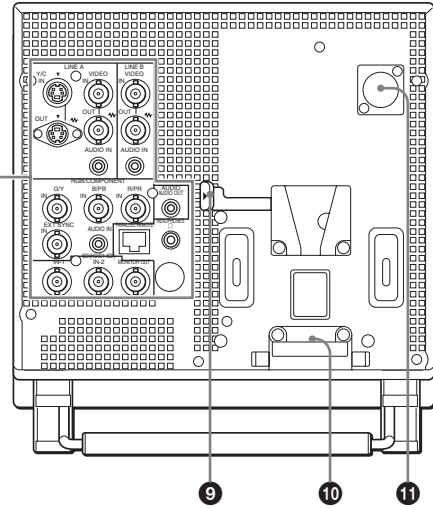
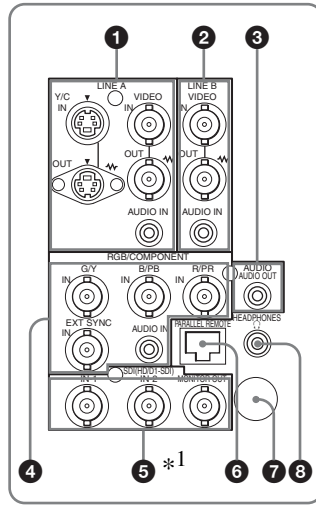

1 LINE A IN/OUT connectors

Input connectors for a Y/C separate signal and for a composite video signal, their loop-through output connectors and input connector for an audio signal. Press the LINE A button on the front panel to monitor the input signal through these connectors. If you input signals to both Y/C IN and VIDEO IN, the signal input to the Y/C IN is selected.

Y/C IN/OUT (4-pin mini-DIN)

These are the input/output connectors for a Y/C separate signal. Connect them to the Y/C separate input/output connectors on equipment such as a VCR, video camera, or another monitor.

VIDEO IN/OUT (BNC)

These are the input/output connectors for a composite video signal. Connect them to the composite video input/output connectors on equipment such as a VCR, video camera, or another monitor.

AUDIO IN (mini jack)

This is the input jack for an audio signal. Connect it to the audio output jack on equipment such as a VCR.

2 LINE B IN/OUT connectors

Input connector for a composite video signal, its loop-through output connector and input connector for an audio signal. Press the LINE B button on the front panel to monitor the signal input through these connectors.

VIDEO IN/OUT (BNC)

These are the input/output connectors for a composite video signal. Connect them to the composite video input/output connectors on equipment such as a VCR, video camera, or another monitor.

AUDIO IN (mini jack)

This is the input jack for an audio signal. Connect it to the audio output jack on equipment such as a VCR.

3 AUDIO OUT connector (mini jack)

The audio signal which is selected by the input select button on the front panel is output. When SDI-1 or SDI-2 is selected, the input signal which is selected in the USER CONFIG menu (on page 28) is output.

4 RGB/COMPONENT input connectors

Analog RGB signal or component (Y, PB, PR) signal input connectors. Press the RGB/COMPONENT button on the front panel to monitor the signal input through these connectors.

G/Y, B/PB, R/PR IN (BNC)

These are the input connectors for an analog RGB and a component (Y, PB, PR) signal. Unless an external sync signal is input, the monitor is synchronized with the sync signal contained in the G/Y signal.

EXT SYNC IN (external sync) connectors (BNC)

When this unit operates on an external sync signal, connect the reference signal from a sync generator to this connector.

Press the EXT SYNC button to use the sync signal through this connector.

Note

When inputting a video signal with the jitters, etc. the picture may be disturbed. We recommend using the TBC (time base corrector).

AUDIO IN (mini jack)

When using an analog RGB or a component signal as a video signal, use this jack for the input of an audio signal. Connect it to the audio output jack on equipment such as a VCR.

5 SDI (HD/D1-SDI) input/output connectors (for LMD-9050 only) SDI (D1-SDI) input/output connectors (for LMD-9030)

There are input connectors (two) for serial digital component signal and output connector for serial digital component monitor signal.

Select by the SDI-1 or SDI-2 button on the front panel.

*1 The SDI (HD/D1-SDI) connectors are printed as SDI (D1-SDI) for LMD-9030.

IN-1 (BNC)

Input the serial digital component signals.

IN-2 (BNC)

Input the serial digital component signals.

MONITOR OUT (BNC)

Output the signals selected by the SDI-1 or SDI-2 button on the front panel.

Note

The signal from the MONITOR OUT connector does not satisfy the ON-LINE signal specifications.

6 PARALLEL REMOTE terminal (modular connector)

Forms a parallel switch and controls the monitor externally.

For safety, do not connect the connector for peripheral device wiring that might have excessive voltage to this modular connector.

For details on the pin assignment and factory setting function assigned to each pin, see page 34.

7 Service terminal

This connector is for use by service personnel only.

8 HEADPHONES jack

The monaural sound is output. When the stereo headphones are inserted, the monaural sound is heard from both left and right channels.

9 EJECT button

While sliding this button, remove the AC adaptor or battery pack.

10 AC adaptor attachment place

Attach the supplied AC adaptor or battery pack.

11 DC 12V IN jack (XLR-type, 4-pin)

Connects the DC 12V external power source to use the monitor.

Installing to the Rack

Up to two models are installed by using the Mount Bracket MB-525 (optional).

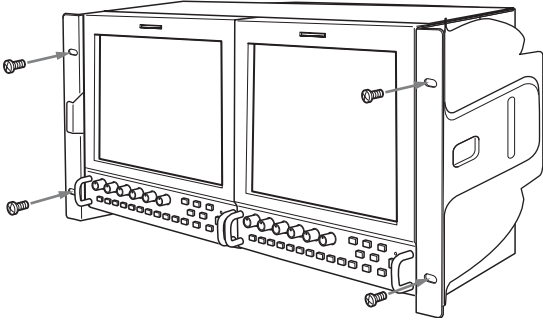

Power Sources

Attaching the AC Adaptor or Battery Pack

Attaching

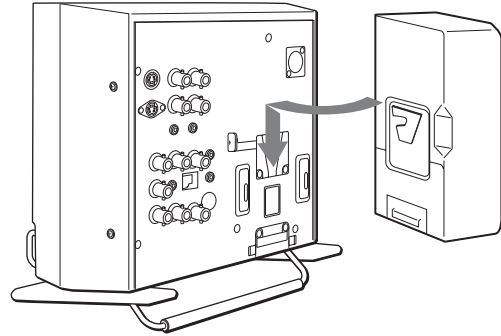

Removing

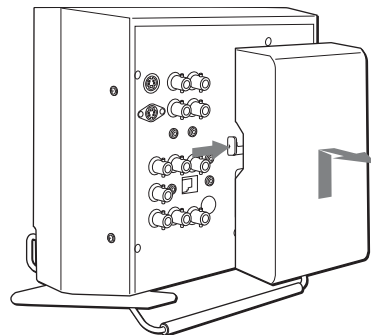

Notes

- Use the supplied AC adaptor for the LMD-9050, LMD-9030 and LMD-9020 only. It is dangerous to use the AC adaptor for models other than these.
- To remove the AC adaptor, first unplug the AC power cord and then remove the AC adaptor.
- When you use the battery pack, refer to the Operating Instructions supplied with the battery pack.

Connecting the AC Power Cord

Attach the AC adaptor to the monitor, and then connect the supplied AC power cord.

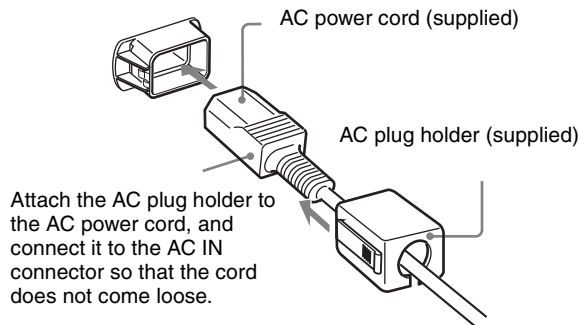

Note

Connect a ground before connecting the AC plug. To disconnect the ground, first disconnect the AC plug and then the ground.

Selecting the Default Settings

When you turn on the unit for the first time after purchasing it, select the area where you intend to use this unit from among the options.

The default setting values for each area

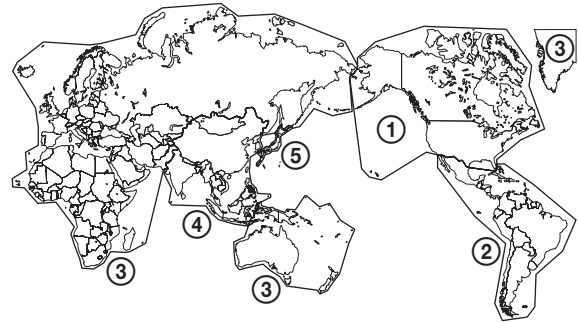

		COLOR TEMP	COMP LEVEL	NTSC SETUP
① NORTH AMERICA		Low	BETA7.5	7.5
② LATIN AMERICA	ARGENTINA	Low	SMPTE	0
	PARAGUAY	Low	SMPTE	0
	URUGUAY	Low	SMPTE	0
	NTSC&PAL-M AREA	OTHER AREA	Low	BETA7.5
③ AFRICA AUSTRALASIA EUROPE MIDDLE-EAST		Low	SMPTE	0
④ ASIA EXCEPT JAPAN	NTSC AREA	Low	BETA7.5	7.5
	PAL AREA	Low	SMPTE	0
⑤ JAPAN		High	SMPTE	0

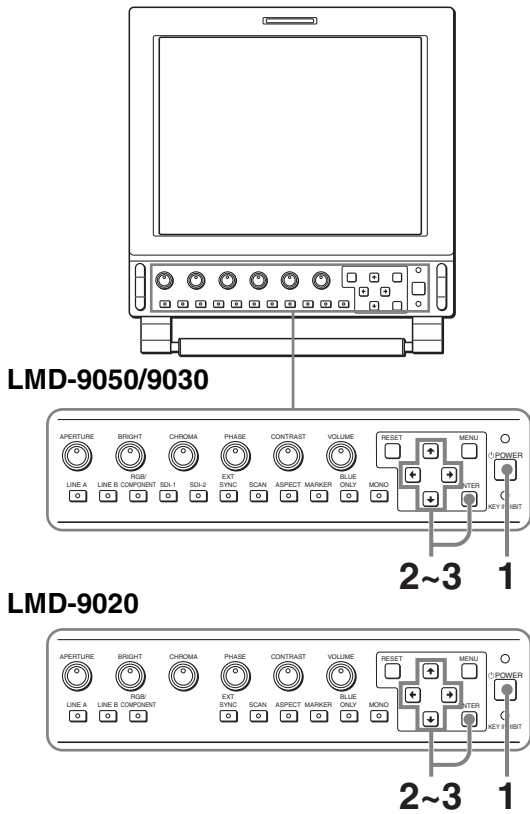

1 Press the POWER switch.
The power is turned on and the SELECT SETTING screen appears.

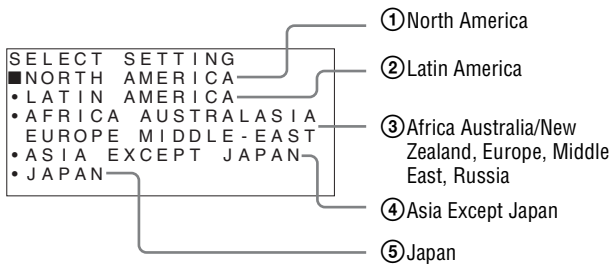

2 Press the **↑** or **↓** button to select the area where you intend to use the unit and press the **→** or ENTER button.
If you select either LATIN AMERICA or ASIA EXCEPT JAPAN, one of the following screens appears.

② If LATIN AMERICA is selected:

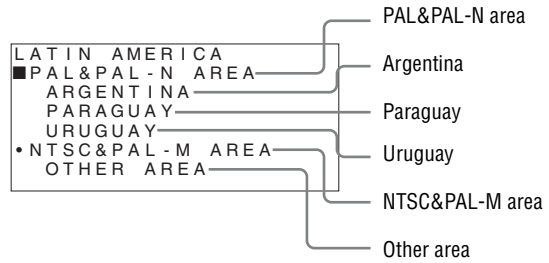

④ If ASIA EXCEPT JAPAN is selected:

Customers who will use this unit in the shaded areas shown in the map below should select NTSC AREA.
Other customers should select PAL AREA.

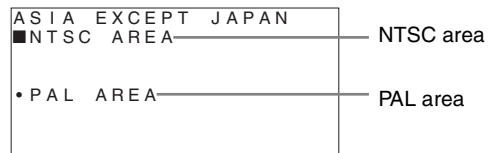

3 Press the **↑** or **↓** button to narrow the area further and then press the **→** or ENTER button.
The SELECT SETTING screen disappears and the menu item settings suitable for the selected area are applied.

Note

When you have selected the wrong area, set the following items using the menu.
COLOR TEMP (on page 27)
COMP LEVEL (on page 28)
NTSC SETUP (on page 28)
See “The default setting values for each area” (on page 22) on the setting value.

Selecting the Menu Language

You can select one of seven languages (English, German, French, Italian, Spanish, Japanese, Chinese) for displaying the menu and other on-screen displays. When JAPAN is selected in the default setting, the language is automatically set to 日本語 (Japanese), but when the other area is selected, it is automatically set to ENGLISH (English).

The current settings are displayed in place of the ■ marks on the illustrations of the menu screen.

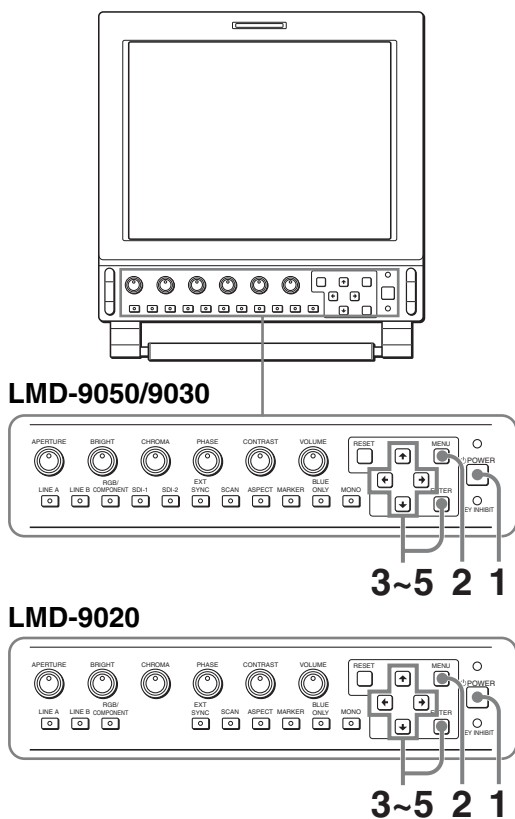

- 1 Press the POWER switch to turn on the unit.
- 2 Press the MENU button.
The menu appears.
The menu presently selected is shown as a yellow button.

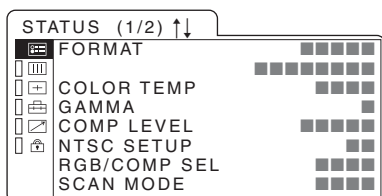

- 3 Press the ↑ or ↓ button to select the USER CONFIG 1/2 (User Configuration 1/2) menu, then press the → or ENTER button.
The setting items (icons) in the selected menu are displayed in yellow.

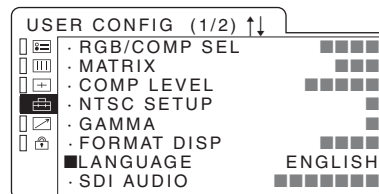

Note

The USER CONFIG menu “SDI AUDIO” is not displayed in LMD-9020.

- 4 Press the ↑ or ↓ button to select “LANGUAGE,” then press the → or ENTER button.
The selected item is displayed in yellow.
- 5 Press the ↑ or ↓ button to select a language, then press the ENTER button.
The menu changes to the selected language.

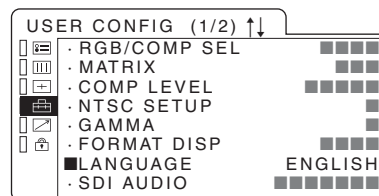

Note

The USER CONFIG menu “SDI AUDIO” is not displayed in LMD-9020.

To clear the menu

Press the MENU button.
The menu disappears automatically if a button is not pressed for one minute.

Using the Menu

The unit is equipped with an on-screen menu for making various adjustments and settings such as picture control, input setting, set setting change, etc. You can also change the menu language displayed in the on-screen menu.

To change the menu language, see “Selecting the Menu Language” on page 24.

The current settings are displayed in place of the ■ marks on the illustrations of the menu screen.

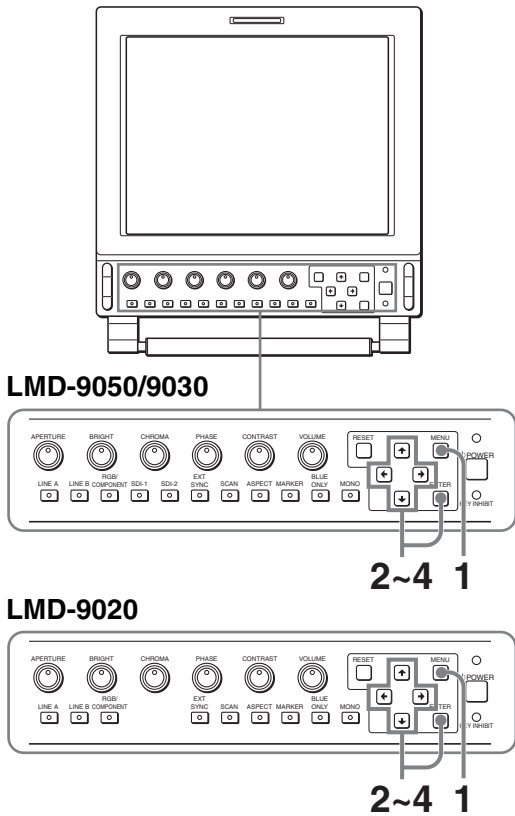

- 1 Press the MENU button.
The menu appears.
The menu presently selected is shown as a yellow button.

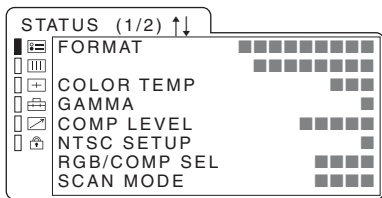

- 2 Use the ↑ or ↓ button to select a menu, then press the → or ENTER button.

The menu icon presently selected is shown in yellow and setting items are displayed.

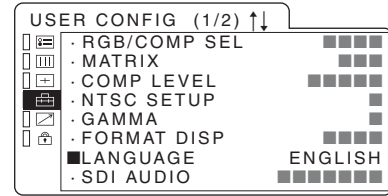

Note

The USER CONFIG menu “SDI AUDIO” is not displayed in LMD-9020.

- 3 Select an item.
Use the ↑ or ↓ button to select the item, then press the → or ENTER button.
The item to be changed is displayed in yellow.

Note

If the menu consists of multiple pages, press ↑ or ↓ to go to the desired menu page.

- 4 Make the setting or adjustment on an item.
When changing the adjustment level:
To increase the number, press the ↑ button.
To decrease the number, press the ↓ button.
Press the ENTER button to confirm the number, then restore the original screen.

When changing the setting:

Press the ↑ or ↓ button to change the setting.
Press the ENTER button to confirm the setting.

Notes

- An item displayed in blue cannot be accessed. You can access the item if it is displayed in white.
- If the key inhibit has been turned on, all items are displayed in blue. To change any of the items, turn the key inhibit to OFF first.
- The operation may be different from the explanation above.

For details on the key inhibit, see page 31.

To clear the menu

Press the MENU button.

The menu disappears automatically if a button is not pressed for one minute.

About the memory of the settings

The settings are automatically stored in the monitor memory.

To reset items that have been adjusted

Pressing the RESET button while you are adjusting any of the menu items resets the menu item to the previous setting.

Adjustment Using the Menus

Items

The screen menu of this monitor consists of the following items.

STATUS (the items indicate the current settings.)

- FORMAT
- COLOR TEMP
- GAMMA
- COMP LEVEL
- NTSC SETUP
- RGB/COMP SEL
- SCAN MODE
- POWER SAVING
- MODEL
- SERIAL NO.

COLOR TEMP/BAL

- COLOR TEMP
- MANUAL ADJ

USER CONTROL

- SUB CONTROL
- PICTURE CONTROL

USER CONFIG

- RGB/COMP SEL
- MATRIX
- COMP LEVEL
- NTSC SETUP
- GAMMA
- FORMAT DISP
- LANGUAGE
- SDI AUDIO (for LMD-9050/9030)
- POWER SAVING
- MARKER
- CENTER MARKER
- MARKER LEVEL
- MARKER MAT
- MARKER LINE
- SCAN

REMOTE PARALLEL

- 1 PIN
- 2 PIN
- 3 PIN
- 4 PIN
- 6 PIN
- 7 PIN
- 8 PIN

KEY INHIBIT

KEY INHIBIT

Adjusting and Changing the Settings

STATUS menu

The STATUS menu is used to display the current status of the unit. The following items are displayed:

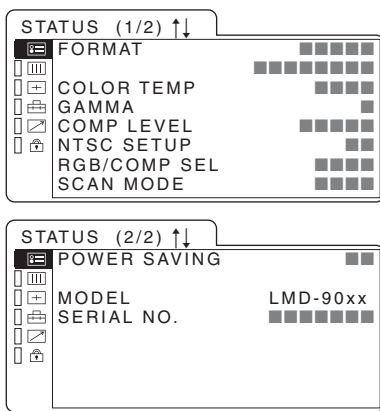

- Signal format
- Color temperature
- Gamma
- Component level
- NTSC setup
- RGB/COMP SEL
- Scan mode
- Power saving
- Model name
- Serial No.

COLOR TEMP/BAL menu

The COLOR TEMP/BAL menu is used for adjusting the picture white balance.

You need to use the measurement instrument to adjust the white balance.

Recommended: Konicaminolta color analyzer CA-210

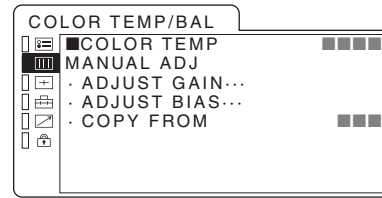

Submenu	Setting
COLOR TEMP	Select the color temperature from among HIGH, LOW and USER setting.
MANUAL ADJ	If you set the COLOR TEMP to USER setting, the item displayed is changed from blue to white, which means you can adjust the color temperature. <ul style="list-style-type: none">• ADJUST GAIN...: Adjusts the color balance (GAIN).• ADJUST BIAS...: Adjusts the color balance (BIAS).• COPY FROM: If you select HIGH or LOW, the white balance data for the selected color temperature will be copied in the user setting.

USER CONTROL menu

The USER CONTROL menu is used for adjusting the picture.

Items that cannot be adjusted depending on the input signal are displayed in blue.

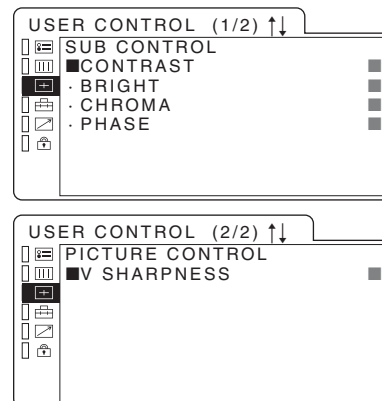

Submenu	Setting
SUB CONTROL	<p>The adjustment range of the CONTRAST, BRIGHT, CHROMA and PHASE controls is adjusted precisely.</p> <ul style="list-style-type: none"> • CONTRAST: Adjusts the picture contrast. • BRIGHT: Adjusts the picture brightness. • CHROMA: Adjusts color intensity. The higher the setting, the greater the intensity. The lower the setting, the lower the intensity. • PHASE: Adjusts color tones. The higher the setting, the more greenish the picture. The lower the setting, the more purplish the picture. <p>For details of input signals and adjustable/setting items, see page 18.</p>
PICTURE CONTROL	<p>You can adjust the picture.</p> <ul style="list-style-type: none"> • V SHARPNESS: A crisp image can be displayed. When the setting is higher, the picture becomes even more crisp.

USER CONFIG menu

You can select a language, etc.

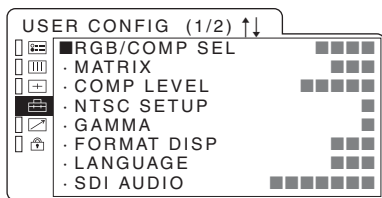

Note

The USER CONFIG menu “SDI AUDIO” is not displayed in LMD-9020.

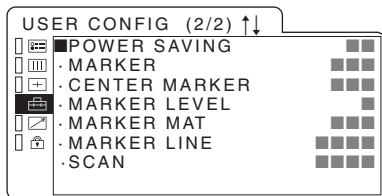

Submenu	Setting
RGB/COMP SEL	When a signal input via the RGB/COMPONENT connector is being monitored, based on the signal being input, select RGB or COMP.
MATRIX	Applied to 480/60I or 480/60P signal. Select 601 or 709.
COMP LEVEL	Select the component level from among three modes. <ul style="list-style-type: none"> • SMPTE for 100/0/100/0 signal • BETA 0 for 100/0/75/0 signal • BETA 7.5 for 100/7.5/75/7.5 signal
NTSC SETUP	Select the NTSC setup level from two modes. The 7.5 setup level is used mainly in North America. The 0 setup level is used mainly in Japan.
GAMMA	Selects the appropriate gamma mode. You can select from among 5 settings. When “3” is selected, the setting is roughly same as the gamma mode of the CRT (2.2).
FORMAT DISP	Select the display mode of the signal format. <ul style="list-style-type: none"> • ON: The mode is always displayed. • OFF: The display is hidden. • AUTO: The format is displayed for about 10 seconds when the input of the signal begins.
LANGUAGE	You can select the menu or message language from among seven languages. <ul style="list-style-type: none"> • ENGLISH: English • DEUTSCH: German • FRANÇAIS: French • ITALIANO: Italian • ESPAÑOL: Spanish • 日本語: Japanese • 中文: Chinese
SDI AUDIO (for LMD-9050/9030)	Selects an SDI audio channel. CH1, CH2, CH3, CH4, CH5, CH6, CH7, CH8, CH9, CH10, CH11, CH12, CH13, CH14, CH15, CH16, OFF
POWER SAVING	Sets the power saving mode on or off. When set to ON, the monitor goes into power saving mode if no signal is input for about one minute.

Submenu	Setting
MARKER	<p>When the frame of the film is displayed on the screen, select the aspect ratio according to the film.</p> <ul style="list-style-type: none"> • When 16:9 aspect ratio is selected with the ASPECT button You can select from among 4:3, 15:9, 14:9, 13:9, 1.85:1, 2.35:1, 1.85:1 & 4:3 and OFF. • When 4:3 aspect ratio is selected with the ASPECT button You can select from among 16:9 and OFF.
CENTER MARKER	Select ON to display the center mark of the picture and OFF not to display.
MARKER LEVEL	<p>Sets the luminance to display the MARKER. When the setting is low, the marker is displayed dark.</p> <p>Note</p> <p>The luminance of the center marker does not change.</p>
MARKER MAT	<p>Selects whether you put mat on the outside of the marker display.</p> <ul style="list-style-type: none"> • OFF: No mat is put. • HALF: Gray mat is put. • BLACK: Black mat is put.
MARKER LINE	<p>Adjust the size of the marker line. Select from among FINE, STANDARD and BOLD.</p> <p>Note</p> <p>The size of the marker line does not change.</p>
SCAN	<p>Enable to select the scan mode by the SCAN select button.</p> <ul style="list-style-type: none"> • OFF: Enable to select NORMAL and UNDER SCAN. • ZERO: Enable to select NORMAL, UNDER SCAN and ZERO SCAN. • ZOOM: Enable to select NORMAL, UNDER SCAN and ZOOM. • ZERO & ZOOM: Enable to Select NORMAL, UNDER SCAN, ZERO SCAN and ZOOM. <p>Note</p> <p>When the aspect ratio is set to 16:9, ZOOM functions.</p>

Scan display

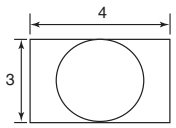
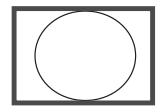
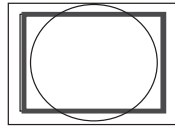
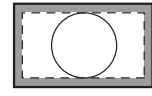
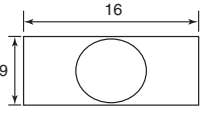
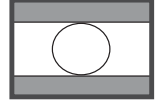
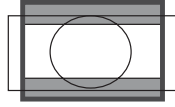
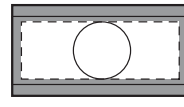
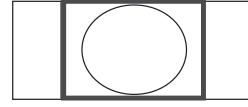
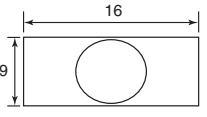
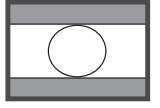
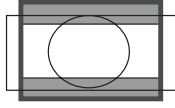
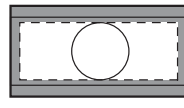
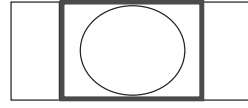
Input	Output			
	ZEROSCAN	NORMAL SCAN (5% OVERSCAN)	UNDER SCAN	ZOOM
				
 <p>SD signal</p>				
 <p>HD signal</p>				

REMOTE PARALLEL menu

Select the PARALLEL REMOTE connector pins for which you want to change the function.

You can assign various functions to 1 to 4 pins and 6 to 8 pins. The following lists the functions you can assign to the pins.

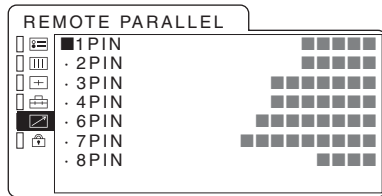

- -- (“--”: No function is assigned.)
- LINE A
- LINE B
- RGB
- COMPONENT
- SDI 1 (for LMD-9050/9030)
- SDI 2 (for LMD-9050/9030)
- TALLY R
- TALLY G
- TALLY AMBER
- NORMAL
- ZEROSCAN
- UNDERSCAN
- ZOOM
- 16:9
- 4:3
- EXT SYNC
- BLUE ONLY
- MONO
- 16:9 MARKER
- 15:9 MARKER
- 14:9 MARKER
- 13:9 MARKER
- 4:3 MARKER
- 1.85:1 & 4:3 MARKER
- 1.85:1 MARKER
- 2.35:1 MARKER
- CENTER MARKER

Note

If you use the PARALLEL REMOTE function, you need to connect cables. For more details, see page 34.

KEY INHIBIT menu

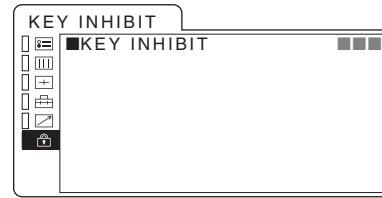

You can lock the setting so that they cannot be changed by an unauthorized user.

Select OFF or ON.

If you set ON, all items are displayed in blue, indicating the items are locked.

The KEY INHIBIT indicator on the front panel lights.

The audio volume is adjustable even when KEY INHIBIT is set to ON.

Troubleshooting

This section may help you isolate the cause of a problem and as a result, eliminate the need to contact technical support.

- **The display is colored in green or purple** → Select the correct input by pressing RGB or COMPONENT button.
- **The unit cannot be operated** → The key protection function works. Set the KEY INHIBIT setting to OFF in the KEY INHIBIT menu.

Specifications

Picture performance

LCD panel	a-Si TFT Active Matrix
Picture size	8.4 type LMD-9050: 170.5 × 127.9 × 213.1 mm (W/H/Diagonal) (6 ³ / ₄ × 5 ¹ / ₈ × 8 ¹ / ₂ inches) LMD-9030/9020: 170.9 × 128.2 × 213.6 mm (W/H/Diagonal) (6 ³ / ₄ × 5 ¹ / ₈ × 8 ¹ / ₂ inches)
Resolution	LMD-9050: 1024 × 768 dots (XGA) LMD-9030/9020: 640 × 480 dots (VGA)
Pixel efficiency	99.99 %
Viewing angle	85°/85°/85°/85° (typical) (up/down/left/right, contrast>10:1)
Aspect	4:3
Display color	16,770,000

Input/output connectors

Input

LINE A input connectors

Y/C input	4-pin mini-DIN (1), Y: 1 Vp-p +3 dB, -6 dB negative synchronization C: 0.286 Vp-p ±3 dB (NTSC burst signal level) 0.3 Vp-p ±3 dB (PAL burst signal level)
-----------	--

VIDEO input

BNC type (1), 1 Vp-p +3 dB, -6 dB negative synchronization

AUDIO input

Mini jack (1), -5 dBu 47 kilohms or higher

LINE B input connectors

VIDEO input

BNC type (1), 1 Vp-p +3 dB, -6 dB negative synchronization

AUDIO input

Mini jack (1), -5 dBu 47 kilohms or higher

RGB/COMPONENT input connectors BNC type (3)

RGB input 0.7 Vp-p +3 dB, -6 dB (Sync On Green, 0.3 Vp-p negative sync.)

Component input

0.7 Vp-p +3 dB, -6 dB (75 % chrominance standard color bar signal)

AUDIO input

Mini jack (1), -5 dBu 47 kilohms or higher

EXT SYNC input
 BNC type (1), 0.3 to 4 V_{p-p}
 ± bipolarity ternary or negative
 polarity binary

SDI (HD/D1-SDI) input (for LMD-9050)
 SDI (D1-SDI) input (for LMD-9030)
 SDI is not available for LMD-9020.

SDI IN-1/SDI IN-2
 Sampling frequency
 D1-SDI: Y/R-Y/B-Y 13.5 MHz
 HD-SDI: Y/PB/PR 74.25 MHz

Quantization
 10 bits/sample

PARALLEL REMOTE input terminal
 Parallel remote
 Modular connector 8-pin (1)

Output

LINE A output connectors
 Y/C output 4-pin mini-DIN (1), Loop-through,
 with 75 ohms automatic terminal
 function

VIDEO output
 BNC type (1), Loop-through, with 75
 ohms automatic terminal function

LINE B output connectors
 VIDEO output
 BNC type (1), Loop-through, with 75
 ohms automatic terminal function

SDI (HD/D1-SDI) MONITOR output (for LMD-9050)
 SDI (D1-SDI) MONITOR output (for LMD-9030)
 SDI is not available for LMD-9020.
 BNC type (1),
 Output signal amplitude:
 800 mV_{p-p} ±10% Output
 impedance:
 75-ohms unbalanced

AUDIO output
 Mini jack (1), Loop-through

HEADPHONES output
 Mini jack (1), Loop-through

Built-in speaker output
 0.5 W (mono)

General

Power AC100 to 240 V, 50/60 Hz,
 0.82 A to 0.42 A
 LMD-9050: DC 12 V, 2.2 A
 LMD-9030: DC 12 V, 1.6 A
 LMD-9020: DC 12 V, 1.5 A

Power consumption
 LMD-9050: 28 W (When AC adaptor
 is attached)
 LMD-9030: 22 W (When AC adaptor
 is attached)
 LMD-9020: 20 W (When AC adaptor
 is attached)

Peak inrush current
 (1) Power ON, current probe method:
 75 A (240 V)
 (2) Hot switching inrush current,
 measured in accordance with
 European standard EN55103-1:
 20 A (230 V)

Dimensions Approx. 216 × 230 × 159.5 mm (not
 including the projection parts)
 (8⁵/₈ × 9¹/₈ × 6³/₈ inches)
 When AC adaptor is installed
 216 × 230 × 210 mm
 (8⁵/₈ × 9¹/₈ × 8³/₈ inches) (w/h/d)

Mass LMD-9050: Approx. 3.2 kg (7 lb 1 oz)
 When AC adaptor is installed
 Approx. 3.9 kg (8 lb 10 oz)
 LMD-9030: Approx. 3.1 kg (6 lb
 13 oz)
 When AC adaptor is installed
 Approx. 3.8 kg (8 lb 6 oz)
 LMD-9020: Approx. 3.0 kg (6 lb
 10 oz)
 When AC adaptor is installed
 Approx. 3.7 kg (8 lb 3 oz)

Operating conditions
 Temperature 0 °C to 40 °C (32 °F to 104 °F)
 Recommended temperature
 20 °C to 30 °C (68 °F to 86 °F)
 Humidity 30% to 85% (no condensation)
 Pressure 700 hPa to 1060 hPa

Storage and transport conditions
 Temperature -20 °C to 60 °C (-4 °F to 140 °F)
 Humidity 0% to 90%
 Pressure 700 hPa to 1060 hPa

Accessories supplied
 AC power cord (1)
 AC power adaptor (1)
 AC plug holder (1)
 Operating Instructions (1)
 CD-ROM (1)
 Warranty Card (1)
 Using the CD-ROM Manual (1)

Optional accessories
 Mounting bracket
 MB-525
 Mounting panel
 MB-528
 Monitor ENG kit
 VF-509
 Rechargeable battery pack
 BP-L90A, BP-L60S, BP-L40A,
 BP-GL95, BP-GL65
 * The sale of the optional accessories
 may end without notice.

Design and specifications are subject to change without notice.

Pin assignment

PARALLEL REMOTE terminal
Modular connector
(8-pin)

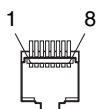

Pin number	Functions
1	Designating LINE A input signal
2	Designating LINE B input signal
3	Designate COMPONENT input signal
4	Designate SDI 1 input signal (for LMD-9050/ 9030)/setting tally lamp Green ON/OFF (LMD-9020)
5	GND
6	Setting tally lamp Red ON/OFF.
7	Selecting zero scan
8	Selecting aspect ratio 16:9

You can allocate functions using the REMOTE PARALLEL menu (see page 31).

Wiring required to use the Remote Control

Connect the function you want to use with a Remote Control to the Ground (Pin 5).

Video signal formats

The unit is applicable to the following signal formats.

Input						Signal standard	
System	Total lines	Active lines	Frame rate ^{*3}	Scanning format	Aspect ratio	Analog	SDI (HD/D1-SDI) ^{*4}
						575/50I (PAL)	625
480/60I (NTSC)	525	483	30	2:1 interlace	16:9/4:3	SMPTE 253M (NTSC: SMPTE 170M)	SMPTE-259M
576/50P	625	576	50	Progressive	16:9/4:3	ITU-R BT.1358	–
480/60P	525	483	60	Progressive	16:9/4:3	SMPTE 293M	–
1080/24PsF ^{*1}	1125	1080	24	2:1 interlace	16:9	SMPTE RP211	SMPTE-292M
1080/50I	1125	1080	25	2:1 interlace	16:9	SMPTE 274M	SMPTE-292M
1035/60I ^{*2}	1125	1035	30	2:1 interlace	16:9	SMPTE 260M/BTA S-001B	SMPTE-292M
1080/60I	1125	1080	30	2:1 interlace	16:9	SMPTE 274M/BTA S-001B	SMPTE-292M
720/60P	750	720	60	Progressive	16:9	SMPTE 296M	SMPTE-292M
720/50P	750	720	50	Progressive	16:9	SMPTE 296M	SMPTE-296M

*1The signal format is displayed as 1080/48I on the screen.

*2The signal format is displayed as 1080/60I on the screen.

A slightly squashed picture is displayed at a little lower position, because the picture is displayed in 1035/1080 picture ratio on a 16:9 screen.

*3 The frame rate is also compatible with 1/1.001.

*4 HD-SDI signal is available for LMD-9050 only.
D1-SDI signal is available for LMD-9050/9030.

Dimensions

Top

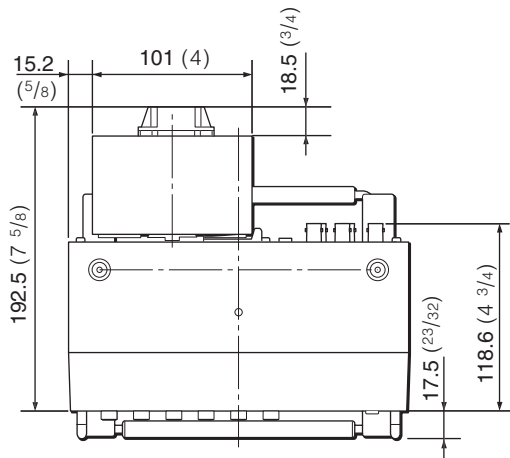

Front

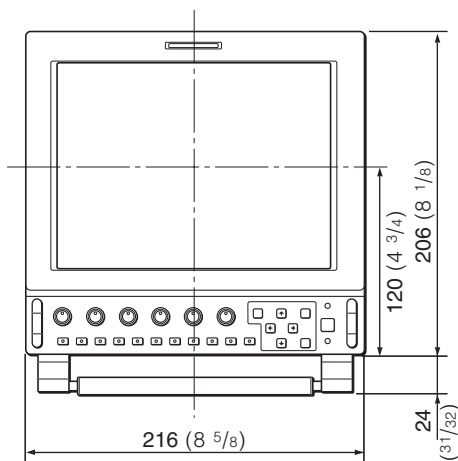

Rear

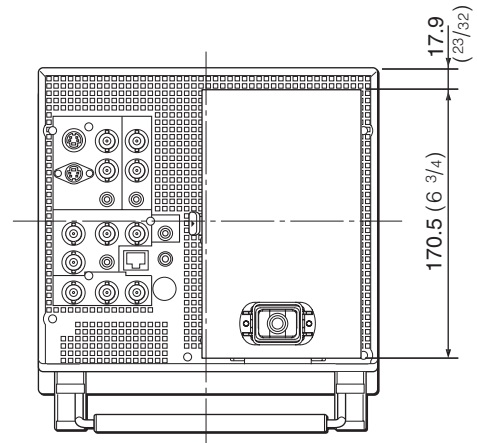

Side

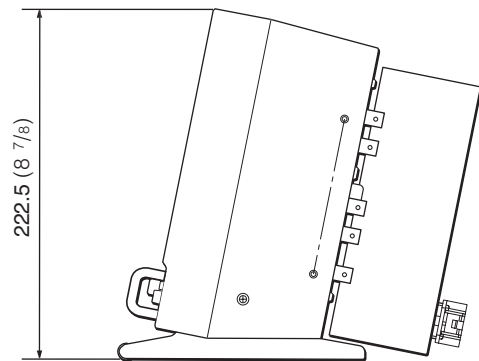
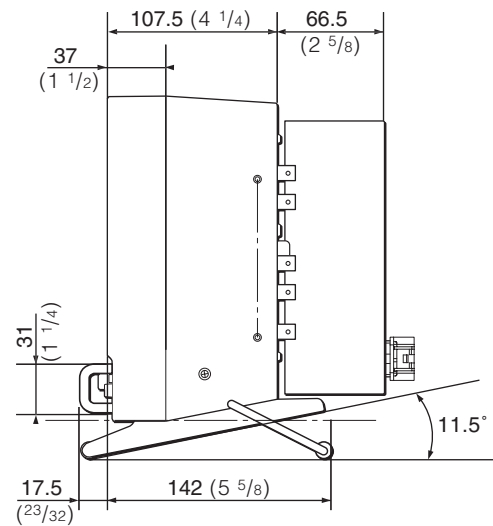

Unit: mm (inches)

* The illustrations above are of the LMD-9050.

